



SP4012 / SP4016 / SP4019

OPERATION MANUAL | SPARE PARTS LIST

**PNEUMATIC POWERED STEEL STRAP
SEALER TOOL WITH SEAL JOINT**



READ ALL INSTRUCTIONS BEFORE OPERATING THE TOOL

GREENBRIDGE
6277 HEISLEY ROAD, MENTOR, OHIO 44060
PHONE: 440.357.1500, FAX: 440.352.9553
WWW.GREENBRIDGE.COM

TABLE OF CONTENTS

- 1) Safety instructions
- 2) Technical data
- 3) Warranty and liability
- 4) Installation
- 5) Operating elements / adjustments
- 6) Operation
- 7) Servicing and cleaning
- 8) Troubleshooting
- 9) Layout – spare parts list

1) SAFETY INSTRUCTIONS



READ THE OPERATING INSTRUCTIONS CAREFULLY



WEAR EYE, FACE, AND HAND PROTECTION WHEN OPERATING THE TOOL.



GENERAL SAFETY INSTRUCTIONS:

The tool must be used by properly trained people. Failure to follow the operating instructions or improper use could cause strap breakage, injuries, or package damages.

Check tool daily, do not use tool with worn or damaged parts. Use original spare parts for replacement. Never modify any tool part.

Do not put fingers, hands or other body parts between the strap and package during the cycle.

It is your responsibility to check the seal joints made by your tool. Training about the weld time adjustment will be useful to check the seal quality in order to avoid severe injury. Never move goods with bad quality seals. Only use specific strap dispenser to dispense the strap. Keep your working area clean and always use the tool in good balance and safety conditions. Never use straps as a means of pulling or lifting goods.

Always use a proper safety strap cutter and keep other people and yourself at a safe distance from strap, always stand to side of strap, away from direction of strap trajectory once cut. Hold the upper strap portion and pay attention that the lower strap will snap forward away from you.

Improper operation, excessive tensioning, use of non-recommended strap, or sharp corners on the package could cause a loss of strap tension and/or strap breakage that could lead to packaging failure or injury. The following is recommended; use edge protectors if package has sharp corners, place the strap correctly around a properly positioned package, stand in safety position (on one side of strap) during strapping cycle, and use the correct strap quality, width, thickness, and break strength as recommended in this manual.

Please save this manual, as it is a part of the tool. This tool is manufactured without any substances which could be dangerous to health. National instructions must be observed for disposal of all the parts.



GENERAL SAFETY INSTRUCTIONS FOR COMPRESSED AIR:

Never operate this tool using bottled air or other gas source. Do not exceed the air pressure range as shown in this operation manual. For all adjustments, repairs or cleaning of the tool, always disconnect air supply. Always use dry, clean and lubricated compressed air.

2) TECHNICAL DATA

TOOL SIZE	
Length:	13.8"
Width:	5.5"
Height:	6.7"
Weight:	8.8 lbs

AIR REQUIREMENT	
Pressure range:	78 - 99 psi
Air consumption:	25cuft/min

SPECIFICATIONS	
Max.Tension force:	87 psi 87 psi 87 psi
Tensioning speed:	12 mt/m – 5mt/m – 4mt/m
Sealing:	Seal: single notch
Joint strength:	80% plastic strap strength*
Level sound emission. Measurement type A (2003/10/CE)	79 dB (A)
Vibrations at handle (2002/44/CE)	<2.5 ms ²

* Depends on strap quality

CHART OF TYPES

MODEL	STRAP	THICKNESS
SP4012 – 1/2" 2000N	R 850N/mm2	0.016" – 0.031"
	R 1100N/mm2	0.016" – 0.025"
SP4016 – 5/8" 2000N	R 850N/mm2	0.016" – 0.031"
	R 1100N/mm2	0.016" – 0.025"
SP4019 – 3/4" 2000N	R 850N/mm2	0.016" – 0.031"
	R 1100N/mm2	0.016" – 0.025"
SP4012 – 1/2" 5500N	R 850N/mm2	0.016" – 0.031"
	R 1100N/mm2	0.016" – 0.025"
SP4016 – 5/8" 5500N	R 850N/mm2	0.016" – 0.031"
	R 1100N/mm2	0.016" – 0.025"
SP4019 – 3/4" 5500N	R 850N/mm2	0.016" – 0.031"
	R 1100N/mm2	0.016" – 0.025"
SP4012 – 1/2" 7500N	R 850N/mm2	0.016" – 0.031"
	R 1100N/mm2	0.016" – 0.025"
SP4016 – 5/8" 7500N	R 850N/mm2	0.016" – 0.031"
	R 1100N/mm2	0.016" – 0.025"
SP4019 – 3/4" 7500N	R 850N/mm2	0.016" – 0.031"
	R 1100N/mm2	0.016" – 0.025"

3) WARRANTY CONDITIONS AND LIABILITY

Greenbridge warrants all its tools and battery chargers during a period of 6 months from the shipping date document. Wear parts are warranted for 45 days, otherwise wear parts are excluded from regular warranty, wear parts are shown on spare parts list (in tool manual).

Warranty includes free replacement parts. The warranty is not valid in case of improper use, lack of maintenance, tampering, arbitrary modifications and reparations, use of non-original parts, disregard of instructions of the operation manual, or missing serial number. No compensation can be claimed for production shutdowns and for damages to people and objects due to tool defects. Greenbridge reserves the right to modify the tools and documentation without any obligation to update previous ones.

Greenbridge warrants all its batteries during a period of 120 days from the shipping date document. The manufacturer is committed to replace it with a free battery only when there are manufacturing defects that make it unfit for use.

4) INSTALLATION

It is recommended to always use a dryer unit near the compressor and a filter-regulator-lubricator unit with pressure gauge (part # 186895) close to the tool air connection to avoid water and dirt in the valves or in the pneumatic motors. Connect the tool to air with quick connector 1/4" and use minimum 8mm or 3/8" internal diameter pipe; max length for flexible pipe 10 m between tool and regulator group. Check that your compressor / air distribution plant is able to supply the right air quantity as shown in the operation manual without losing pressure

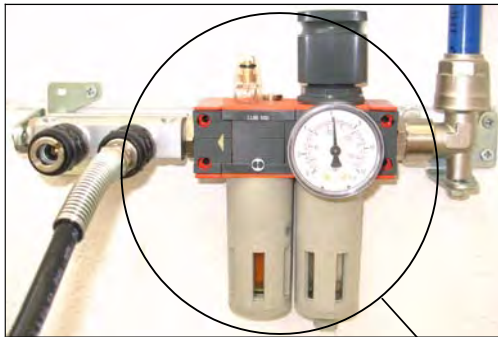

186895

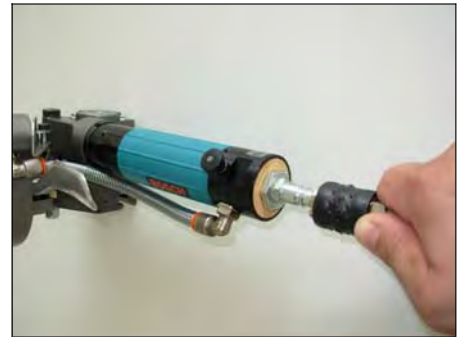

5) OPERATING ELEMENTS AND ADJUSTMENTS

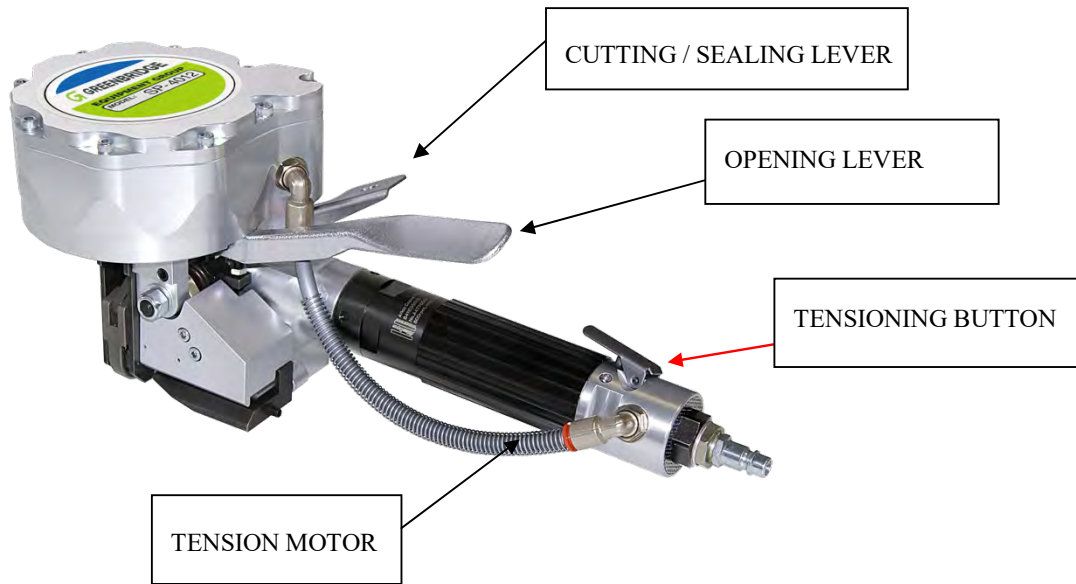

Adjusting strap tension

The strap tension can be adjusted with a screwdriver by turning the screw, as shown, on pneumatic motor (pic.A). Turning clockwise the tension will be reduced, and counter clockwise it will be increased – do not exceed counter clockwise adjustment –.

(A)



Feed wheel gap adjustment

It is possible to adjust the gap between the feed-wheel and the gripper plate in order to change the pressure on strap; unscrew the locking screw (pic.B1), set strap plate so that the standard gap between feed-wheel and gripper plate is (0.0039"-0.0078"). Turning clockwise decreases the gap, turning counter clockwise increases the gap (pic.B2), after adjusting the gap lock the screw.

(B1)



(B2)



6) OPERATION

The model SP4000 series is designed to strap packages with steel strap. The strap is fed around the package manually and inserted in the tool, tensioned, cut and then sealed with a seal.

Slip the strap into the seal and wrap it up around the package; then make the lead end of the strap pass a second time into the seal, then bend the strap (**pic.C1**); squeeze the opening lever to open the tool and load the top layer of strap into the tool (**pic.C2**), press tensioning button to tighten strap and hold it until desired tension is reached (**pic.C3**).

Once strap tension is complete, press sealing lever and hold it until the seal and cut are complete (**pic.C4**); once the seal and cut cycle is over, squeeze the opening lever to take the strap out of the tool (**pic.C5**).

Finally, check if the seal joint is sufficient, it is important to know the proper depth of the notch in the seal for maximum efficiency (**fig. C6**).

(C1)



(C2)



(C3)



(C4)



(C5)



(C6)



7) SERVICING - CLEANING

DISCONNECT TOOL FROM COMPRESSED AIR LINE BEFORE ANY SERVICE OR CLEANING

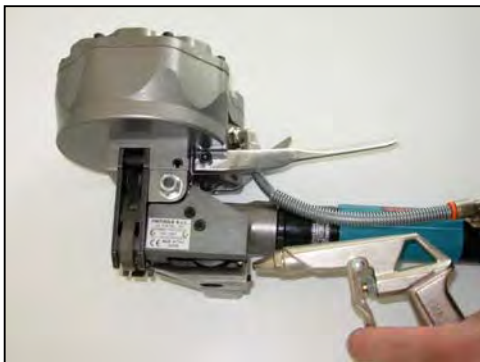

Use compressed air to clean the feed wheel area as shown.

8) TROUBLESHOOTING

PROBLEM
REMEDY
The tension of the strap is too low
Check the air pressure (min.78 psi) Check if the filter / lubricator group is damaged or dirty. Check if the pneumatic motor is damaged or dirty (contact the after sale service). Check the power adjusting screw on the pneumatic motor.
The feedwheel slips and damages the strap
Check if the feed wheel is dirty or damaged. Adjust the gap between feed wheel and the gripper plate (around 0.0039" - 0.0078")
The strap is breaking during tension
Adjust the motor power—too much tension force. Check if the strap characteristics are right for the strapping tool.
The tensioned strap goes sideways and curls
Adjust the motor power—too much tension force. Check if the strap characteristics are right for the strapping tool.
Air is leaking
The gaskets may need to be replaced (contact the after sale service) Check the air fitting and air pipe.
Insufficient crimping of the seal
Check the air pressure (min. 78 psi). Check if there are some loose or damaged parts in the sealing group Check if the strap characteristics are right for the strapping tool Check the seal quality
The strap is not cut properly
Check the air pressure (min.78 psi). Check if the strap characteristics are right for the strapping tool. Check for worn or damaged parts (contact the after sale service). The cutter is worn or damaged.

9) SPARE PARTS LIST

Ed. 06/17

GREENBRIDGE PART #	ITEM	DESCRIPTION	QTY		
	AZOR102	OR102	1		
189727	A00062	CUTTER	1	§	*
190259	A000155	SUSPENSION BRACKET	1		
208248	A007380	PISTON COER ASSEMBLY	1		
208249	A007390	MAIN FRAME ASSEMBLY	1		
207134	B100032	PIPE 6X8(Length meters)	1		
207134	B100032	8MM BLACK TUBING (PER 6")	0,3		*
189122	B100296	PIVOT SPRING RETAINING SCREW	1		
189137	B100310	SWING ELBOW RL31 8 1/4 (2L31011)	2		*
189672	B200104	WASHER 458-33/19C	1		
189674	B200105	WASHER 458-33/21C	2		
189920	B200308	FAST AIR CONN. ANI 64MF 8X10	1		
189105	B200309	¼" AIR FITTING	1		
189177	B300021	O-RING 2125 (D32)	1		
289860	B300026	OIL GASKET G 12X16X3	1		
189861	B300083	O-RING OR2031 (D8)	1		
189862	B300084	O-RING OR4400 (D101)	2		
189673	B300085	O-RING OR16X2	4		
189863	B300089	GASKET AIRZET PR12	2		
189864	B300090	GASKET AIRZET PR8	1		
208250	B300543	O-RING 6X1.5	1		
208251	B300547	O-RING 3375	1		
189180	B400001	ROLLER BEARING BK0810	1		
189182	B400002	BEARING 7200BE 2RS	1		
191284	B400007	BEARING 6201 2Z	1		
189865	B400082	ROLLER BEARING BK 1412	1		
189699	B500034	SCREW UNC 10x5/8"	8		*
189179	B500043	SCREW ECOFIX M5X12 ZINC	2		
189732	B500052	NUT M6 H5 8.8 UNI 5588 ZINC	1		
189163	B500053	SELFLOCK.NUT M8 H10 DIN982	1		
189719	B500067	SCREW M4X6 UNI 5931	2		
190034	B500073	NUT M5	1		
189867	B500093	SCREW M5X25 UNI5933	1		
189868	B500094	SCREW UNC 1/4"X1"	1		
190035	B500095	SCREW M5X18 UNI5927	1		
189700	B500097	SELFLOCK.NUT M5H5 DIN985 ZIN	1		
189163	B500098	SELFLOCK. NUT M8H8 DIN985 ZIN	1		
189869	B500099	WASHER 8.4X16 M8 UNI6592 ZIN	2		
189870	B500106	SCREW 10X80XM8 ISO7379	1		
189835	B500142	SCREW M8X10X1 UNI5923	1		
189744	B500388	SCREW M5X5 UNI5927	1		
189873	B500434	SCREW M5X12 UNI5739	1		
208247	B500462	WASHER SCHNORR R150 DIAM.5	9		
189144	B600010	GUIDE SOCKET BM 1010	2		
189192	B600011	WASHER A10X16X0,5	1		
189183	B600012	CIRCLIP A10 DIN471	1		
189193	B600014	WASHER PS 22x30x0,1	VAR		
189194	B600015	WASHER PS 22x30x0,5	VAR		
189279	B600016	WASHER PS 10x16x1	1		

189506	B600017	WASHER PS 22x30x1,5	1		
189767	B600389	WASHER PS 22x30x0,2	VAR		
189130	B700029	PIN 6x12 DIN6325	2		
189874	B700100	SPRING PIN.6X50 UNI6874	1		
190063	B700101	PIN 6X28 DIN6325	1		
189875	B700102	SPRING PIN 4X14 UNI6874	1		

GREENBRIDGE PART #	ITEM	DESCRIPTION	QTY		
190143	B700103	PIN 3X10 UNI6873	1		
189510	D000670	VALVE SPRING	1		*
189484	D001740	CROWN	1		
189181	D001750	WORM GEAR	1		
189726	D003110	CUTTER SPRING	1		*
189725	D003120	SPRING	1		*
189879	D003400	SPACER	2		
189880	D003410	LINK PIN	1		
189718	D003420	SPACER	1		
189881	D003440	JAWS PIN	2		
189720	D003450	FEEDWHEEL GAP ADJUSTER	1	§	*
189882	D003460	PISTON SPACER	1		
189883	D003470	PISTON SHAFT	1		
189884	D003480	ANVIL 3/4"	2		*
189885	D003490	ANVIL 5/8"	2		*
189886	D003500	ANVIL 1/2"	2		*
189887	D003510	TOP LINK	2		*
189721	D003520	JAW	2		*
189888	D003540	FRONT PLATE 1/2"	1		*
189889	D003550	FRONT PLATE 5/8"	1		*
189890	D003560	FRONT PLATE 3/4"	1		*
189891	D003570	REAR PLATE 1/2"	1		*
189892	D003580	REAR PLATE 5/8"	1		*
189893	D003590	REAR PLATE 3/4"	1		*
189894	D003600	PISTON	1		
189895	D003610	GEARBOX BEARING SUPPORT	1		
189896	D003620	FEED WHEEL SHAFT	1		
189897	D003630	FEED WHEEL SHAFT SUPPORT	1		
189676	D003640	FEED WHEEL	1	§	*
189898	D003650	3/4" STRAP GUIDE FOOT	1		
189899	D003660	5/8" STRAP GUIDE FOOT	1		
189900	D003670	1/2" STRAP GUIDE FOOT	1		
189901	D003680	FEED WHEEL COVER	1		
189902	D003690	OUTLET DISTRIBUTOR	1		
189903	D003700	MIDDLE DISTRIBUTOR	1		
189904	D003710	VALVE PIN	1		
189905	D003730	SEALING LEVER	1		
189906	D003740	GEARBOX BODY	1		
189907	D003750	MAIN BODY	1		
189908	D003760	COVER	1		
189646	D003770	GASKET COVER	1		*
189909	D003790	OPENING LEVER	1		
189910	D004280	AIR PIPE PROTECTION SPRING	1		
	8411035101	ATLAS COPCO PNEUMATIC MOTOR 2000N	1		
205779	8411035093	ATLAS COPCO PNEUMATIC MOTOR 5500N	1		
	8411035085	ATLAS COPCO PNEUMATIC MOTOR 7500N	1		

	§	WEARING PART
	*	PART THAT SHOULD BE STOCKED

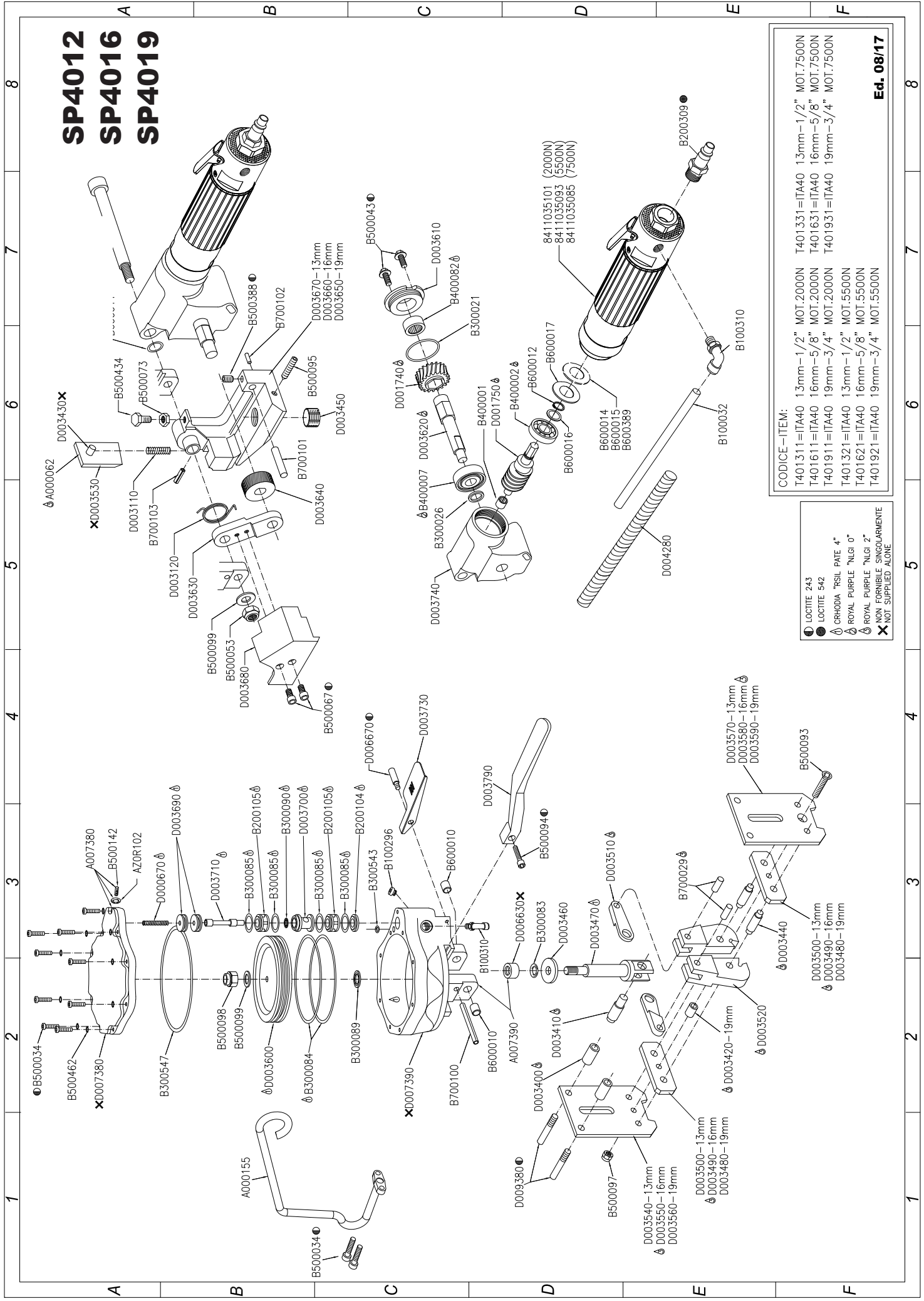

SP4012 SP4016 SP4019

CODICE - ITEM:

T401311=ITA40	13mm-1/2"	MOT.2000N	T401331=ITA40	13mm-1/2"	MOT.7500N
T401611=ITA40	16mm-5/8"	MOT.2000N	T401631=ITA40	16mm-5/8"	MOT.7500N
T401911=ITA40	19mm-3/4"	MOT.2000N	T401931=ITA40	19mm-3/4"	MOT.7500N
T401321=ITA40	13mm-1/2"	MOT.5500N	T401621=ITA40	16mm-5/8"	MOT.5500N
T401621=ITA40	16mm-5/8"	MOT.5500N	T401921=ITA40	19mm-3/4"	MOT.5500N

- LOCTITE 243
- LOCTITE 542
- ⊕ CRHODIA "FSLI PATE 4"
- ⊕ ROYAL PURPLE "NLGI 0"
- ⊕ ROYAL PURPLE "NLGI 2"
- ⊕ NON FORNIBILE SINGOLARMENTE
- ✕ NOT SUPPLIED ALONE

**BOSCH 0 607 951 443 –
GREENBRIDGE PART # 401-0333 TENSION MOTOR**

0 607 951 333; 336
Issue | 05-10-07
Stand | **Fig./Abb. 1**

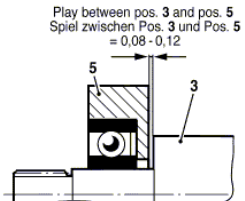
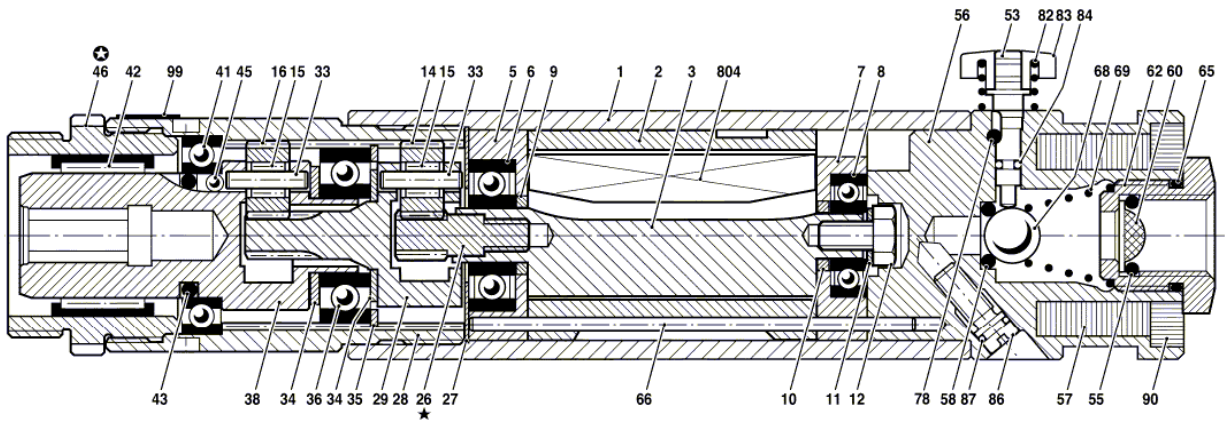
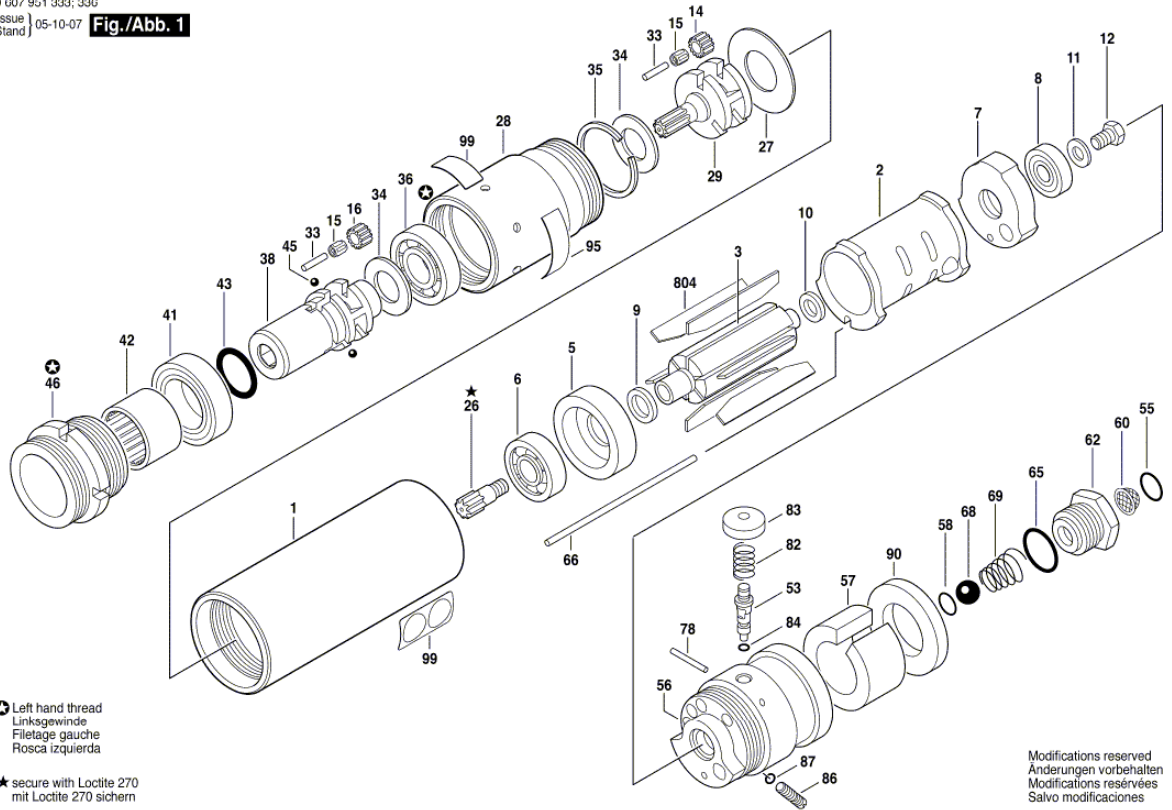

Torque values
 Anzugsmomente
 Couple de serrage
 Pares de apriete
 Pos. 12 = 3,0 - 3,5 Nm
 26 = 4,0 - 5,0 Nm
 28 = 40,0 - 48,0 Nm
 46 = 40,0 - 44,0 Nm
 56 = 15,0 - 18,0 Nm

⚙️ Left hand thread
 Linksgewinde
 Filetage gauche
 Rosca izquierda

★ secure with Loctite 270
 mit Loctite 270 sichern

Dimensions in mm
 Maße in mm
 Cotes en mm
 Medidas en mm

Modifications reserved
 Änderungen vorbehalten
 Modifications réservées
 Salvo modificaciones

**BOSCH 0 607 951 444 –
GREENBRIDGE PART # 401-0334 TENSION MOTOR**

0 607 951 333; 330
Issue | 05-10-07 | **Fig./Abb. 1**
Stand

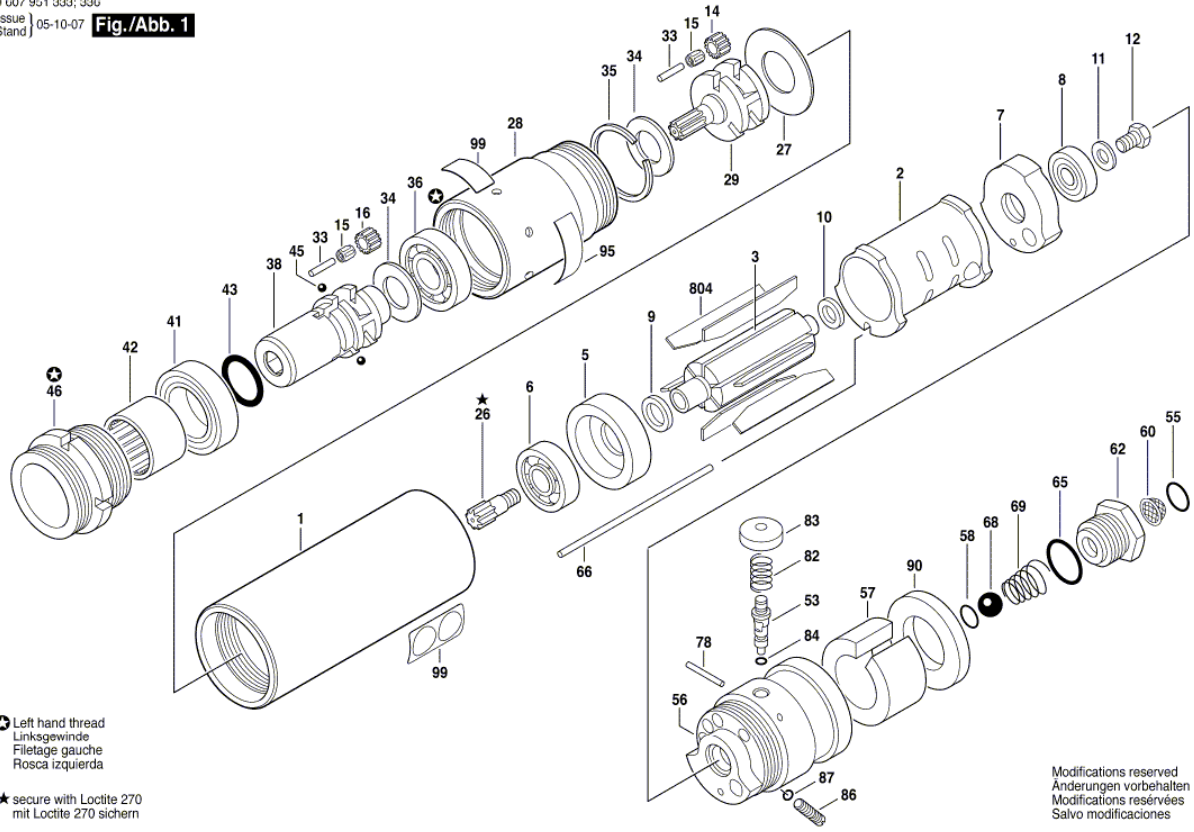

⊖ Left hand thread
Linksgewinde
Filetage gauche
Rosca izquierda

★ secure with Loctite 270
mit Loctite 270 sichern

Modifications reserved
Änderungen vorbehalten
Modifications réservées
Salvo modificaciones

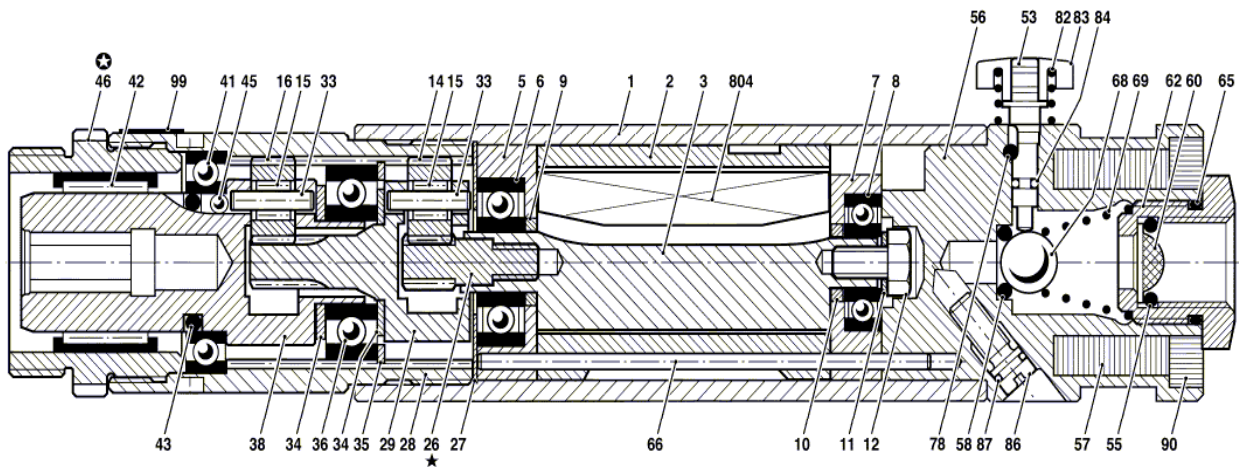

Play between pos. 3 and pos. 5
Spiel zwischen Pos. 3 und Pos. 5
= 0,08 - 0,12

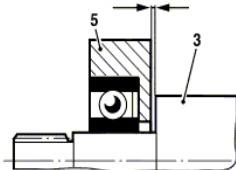

Torque values
Anzugsmomente
Cotes de serrage
Pares de apriete
Pos. 12 = 3,0 - 3,5 Nm
26 = 4,0 - 5,0 Nm
28 = 40,0 - 48,0 Nm
46 = 40,0 - 44,0 Nm
56 = 15,0 - 18,0 Nm

⊖ Left hand thread
Linksgewinde
Filetage gauche
Rosca izquierda

★ secure with Loctite 270
mit Loctite 270 sichern

Dimensions in mm
Maße in mm
Cotes en mm
Medidas en mm

Modifications reserved
Änderungen vorbehalten
Modifications réservées
Salvo modificaciones

**BOSCH 0 607 951 446 –
GREENBRIDGE PART # 401-0335 TENSION MOTOR**

0 607 951 334; 335
Issue | 05-10-07
Stand | **Fig./Abb. 1**

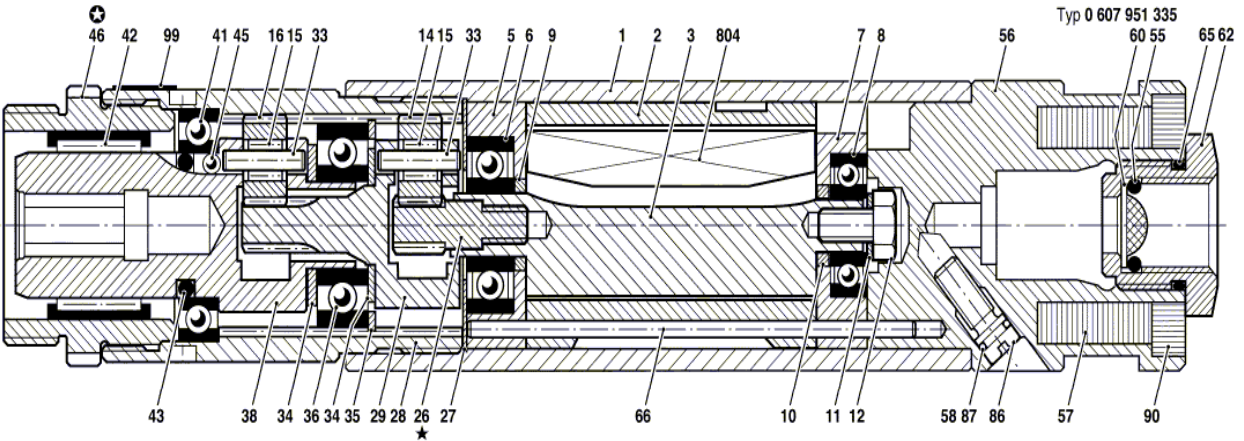
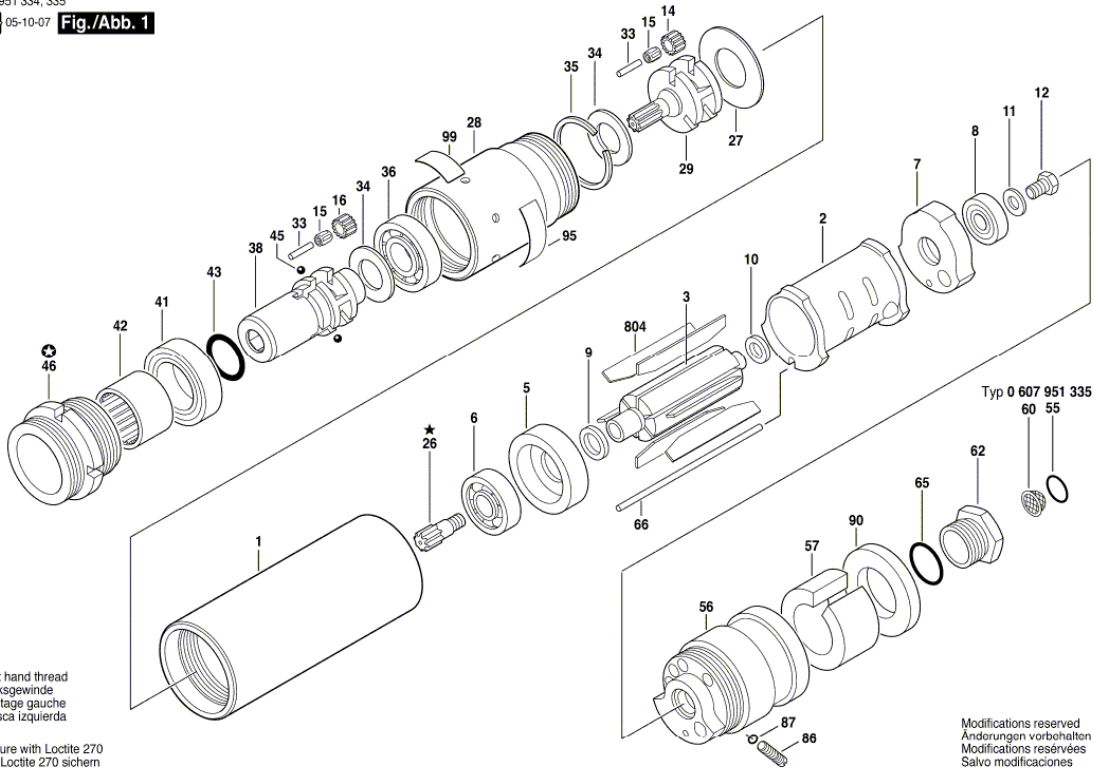

Torque values
Anzugsmomente
Couple de serrage
Pares de apriete
Pos. 12 = 3,0 - 3,5 Nm
26 = 4,0 - 5,0 Nm
28 = 40,0 - 48,0 Nm
46 = 40,0 - 44,0 Nm
56 = 15,0 - 18,0 Nm

⊖ Left hand thread
Linksgewinde
Filetage gauche
Rosca Izquierda

★ secure with Loctite 270
mit Loctite 270 sichern

Dimensions in mm
Maße in mm
Cotes en mm
Medidas en mm

Modifications reserved
Änderungen vorbehalten
Modifications réservées
Salvo modificaciones

MODEL: Series SP4000



MACHINE TYPE:

PNEUMATIC STEEL STRAPPING TOOL SEAL JOINT

GREENBRIDGE

6277 Heisley Road Mentor, Ohio 44060
Tel. 440-357-1500 Fax 440-352-9553 www.greenbridge.com