





SOLUTIONS FOR BUNDLING PROTEINS

PC1000SS AUTOMATIC STRAPPING MACHINE

The PC1000SS is a high-speed, stainless steel automatic strapping machine for protein processing operations. It is equipped with industry-leading features. The PC1000SS offers optimal performance, high-cycle speed, and is easy to maintain and sanitize.

It's the most cost-effective strapping solution in its class.

The PC1000SS for Poultry, Meat + Fish

-  **Designed for harsh environments**
-  **High-speed reliability**
-  **Easy to operate**
-  **Easy to maintain + sanitize**

FEATURES

- All SUS 304 stainless steel
- Cycle speed up to 65 straps per minute (based on arch size)
- German DC brushless motor technology
- 30% fewer parts – no belts, clutches or pulleys
- Waist-high quick change coil + strap feed; coil retracts back into cabinet
- Easy access operating control panel
- One-piece strap chute
- Easy access strap chute, no tools required
- Front foot bar pedal plus movable foot switch
- Sensor-controlled heater
- End of coil strap ejector/loop ejector
- Electronic brake/Auto loader
- Adjustable table height from 32" to 36"
- **SUPER FAST!**
Up To 65 Straps Per Minute
- Easy to move + secure in place with lockable casters
- Choice of two arch sizes. Special sizes available.
- Roller top standard on arches 33" wide or wider



WHERE THE RUBBER MEETS THE ROAD.

PC1000SS EQUIPMENT SPECS



SPECIFICATIONS

Cycle Rate	Up to 65 straps per minute based on arch + package size
Package Weight	Up to 100 lbs.
Strap Tension	Up to 100 lbs.
Polypropylene Strap	1/4"–1/2", 5mm, 6mm, 9mm, 12mm
Electrical Requirements	110V 60Hz 1 Phase
Shipping Weight	450 lbs.

DIMENSIONS

PC1000SS

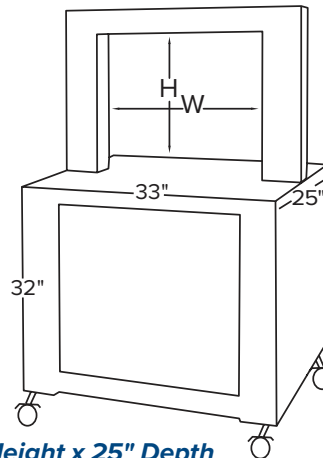

33" Width x 32" Height x 25" Depth



Greenbridge has the most extensive portfolio of PET and PP strap and cord in the industry.

Please contact us for a recommendation.

ABOUT GREENBRIDGE

Founded in 1974 as Polychem, we rebranded in April 2021 as Greenbridge to reflect our commitment to providing proactive solutions to customers across North America seeking to achieve more sustainable, high-performing operations. Our early reputation was based on our quality polyester, polypropylene and cord strapping. Today, years of growth and strategic acquisitions have made Greenbridge a leading end-of-line packaging supplier, with integrated solutions that encompass tools, equipment, systems, and services that help tame the most challenging supply chains.

Greenbridge is committed to the safety of our team, the quality of our products and services, investing in continuous improvement, advancing the circular economy, and fostering sustainable customer success.

It's easy to find a supplier to sell you equipment.

It's another thing to find one who understands your business.

Talk to Greenbridge.

 GREENBRIDGE

