

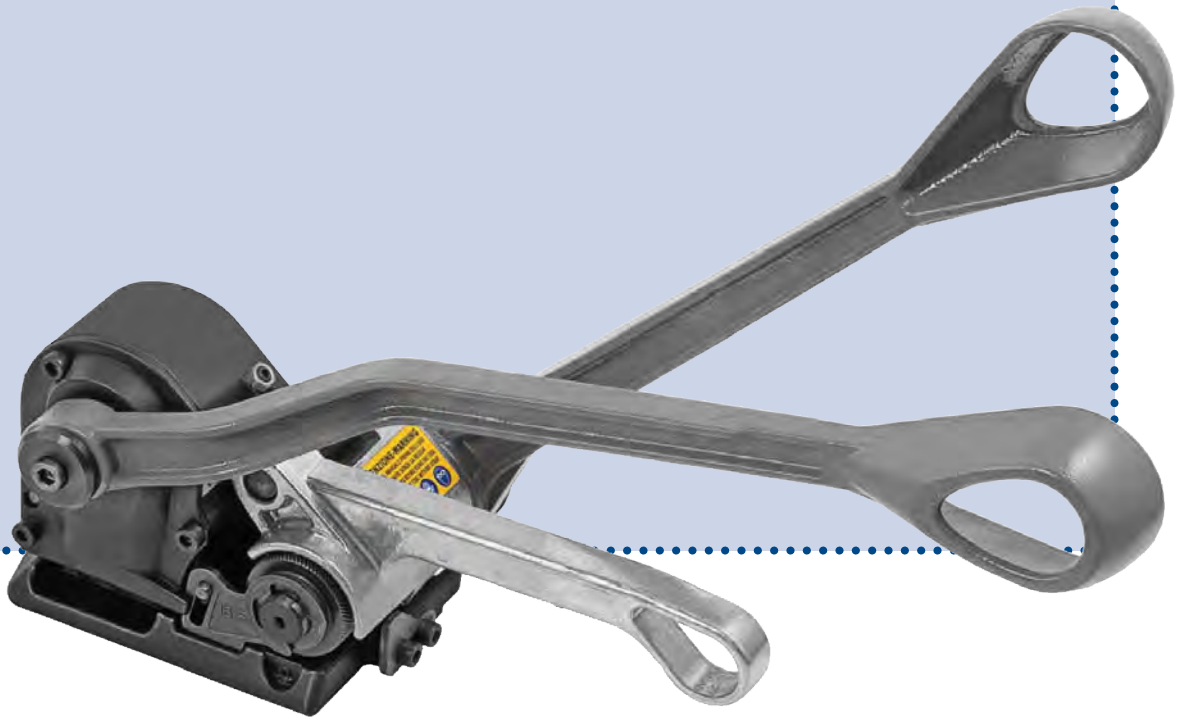

SM3000

OPERATION MANUAL | SPARE PARTS LIST

MANUAL SEALLESS STRAPPING TOOL STEEL STRAP



CE

READ ALL INSTRUCTIONS BEFORE OPERATING THE TOOL

GREENBRIDGE

6277 HEISLEY ROAD, MENTOR, OHIO 44060

PHONE: 440.357.1500, FAX: 440.352.9553

WWW.GREENBRIDGE.COM

ED. 11/21

TABLE OF CONTENTS

- 1) Safety instructions
- 2) Technical data
- 3) Warranty and liability
- 4) Operating elements / adjustments
- 5) Operation
- 6) Servicing and cleaning
- 7) Troubleshooting
- 8) Layout – spare parts list

1) SAFETY INSTRUCTIONS



READ THE OPERATING INSTRUCTIONS CAREFULLY



WHEN OPERATING THE TOOL, WEAR EYE, FACE AND HAND SAFETY PROTECTION



GENERAL SAFETY INSTRUCTIONS :

The tool must be used by properly trained personnel. Failure to follow the operating instructions or improper use of tool can cause strap breakage, injuries, or package damage.

Check tool daily, do not use tool with worn or damaged parts. Promptly replace them by trained people and use original spare parts. Never modify any tool part.

Do not put fingers, hands or other body parts between the strap and package during the cycle.

It is your responsibility to check the joints made by your tool. Seal control will be useful to check the seal quality in order to avoid severe injury. Never move goods with bad quality seals. Use only specific strap dispenser to dispense the strap. Always use the tool in good balance and safety conditions. Never use straps as a means of pulling or lifting goods.

Always use a proper safety strap cutter and keep other people and yourself at a safe distance from strap, always stand to side of strap, away from direction of strap trajectory when cut. Hold the upper strap portion and pay attention that the lower strap will snap forward away from you.

Improper operation, excessive tensioning, use of non-recommended strap, sharp corners on the package could cause in a loss of strap tension and/or strap breakage that could lead to packaging failure or injury. It is recommended to use edge protectors if package has sharp corners, to place the strap correctly around a properly positioned package, stand in safety position (on one side of strap) during strapping cycle, and use the correct strap quality, width, thickness, and strength as recommended in this manual.

Please save this manual, as it is a part of the tool. This tool is manufactured without any substances which could be dangerous to health. National instructions must be observed for disposal of all the parts.

2) TECHNICAL DATA

DESCRIPTION OF THE TOOL: The tool model SM3000 is designed to strap packages with steel strap.

TOOL SIZE		
Length:		350mm – 13.8”
Width:		140mm – 5.5”
Height:		260mm – 10.2”
Weight:		4.4 kgs – 9.7lbs
SPECS.		
Max.Tension force:		5500N
Gear ratio		1:18
Sealing:		Seal-less
Joint strength:		80% of strap strength*

* depends of strap quality

CHART OF TYPES

ITEM	MODEL	STRAP	THICKNESS
T309909	SM3000 13/16/19mm 1/2"-5/8"-3/4"	R 850N/mm ² R 1100N/mm ²	.018" – .028" .018" – .025"

3) WARRANTY CONDITIONS AND LIABILITY

GREENBRIDGE warrants all its tools during a period of 3 months from the shipping date document. Warranty includes free replacement of faulty parts ex works. The warranty is not valid in case of improper use, lack of maintenance, tampering, arbitrary modifications and reparations, use of non-original parts, disregard of instructions of the operation manual, and missing serial number, exceptional events. The warranty excludes the wearing parts shown on spare parts list. No compensation can be claimed for production shutdowns and for damages to people and objects due to tools defects. GREENBRIDGE reserves the right to modify the tools and documentation without any obligation to update previous ones.

4) OPERATING ELEMENTS AND ADJUSTMENTS

DO NOT OPERATE THE TOOL WITHOUT STRAP, YOU COULD DAMAGE THE FEEDWHEEL

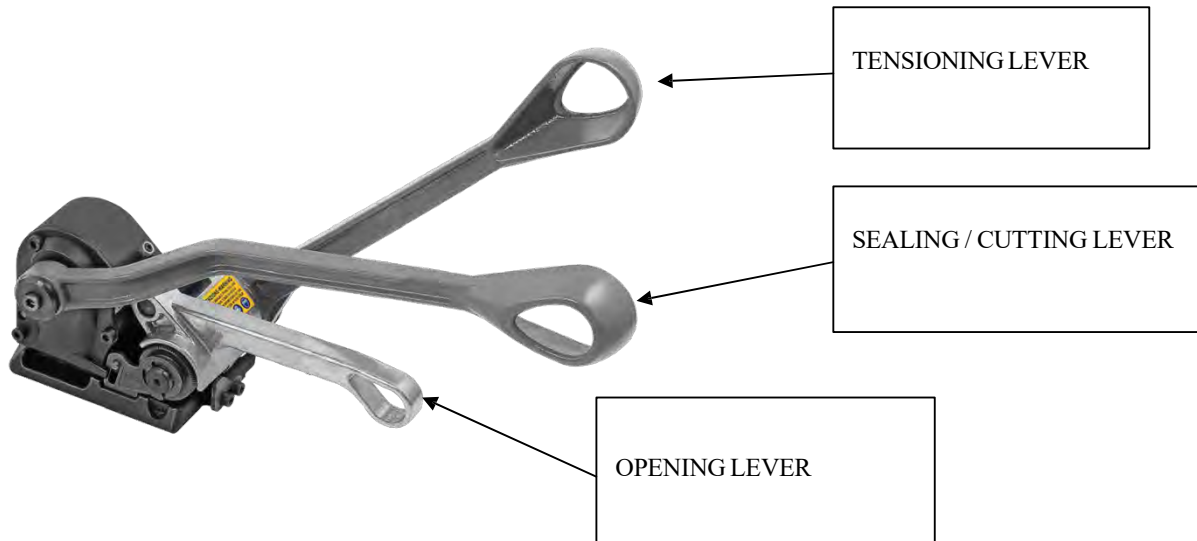

Seal and cut adjustment

The setting of the cutting depth must correspond to the thickness of the strap used. Release the locknut holding the adjusting screw, turn the adjusting screw clockwise to reduce the depth, and counter clockwise to increase it. Tighten locknut. (pic. A)

(A)



Feedwheel gap adjustment

(B1)



(B2)



0.2mm
0.008"

It is possible to adjust the gap between feed wheel and gripper in order to change pressure on strap; turn the locking screw (pic.B1) clockwise to increase the gap, counter clockwise to reduce the gap. The standard gap is 0.2mm (0.008") (pic.B2).

Strap size conversion

To set the tool for 13mm 1/2" – 16mm 5/8" – 19mm 3/4" strap sizes follow the below instructions:

(E1)



13mm
1/2"

(E2)



16mm
5/8"

(E3)



19mm
3/4"

(E4)



To set the guide, unscrew the locknut and the pin, move the shims to required setting. Tighten the locknut to save setting.

(E5)



(E6)



(E7)



(E8)



To replace the side strap guide remove the safety circlip (pic.E5), squeeze the opening lever (pic.E6) and remove the guide (pic.E7-E8) replacing with required size.

5.) OPERATION

Wrap the parcel with the strap, as shown in pic.F1, holding the tip of the strap with left hand and wrap the strap with right hand; open the tool by squeezing the opening lever and sealing lever with right hand then insert the two straps against the front/rear strap guides(pic.F2-F3).

(F1)

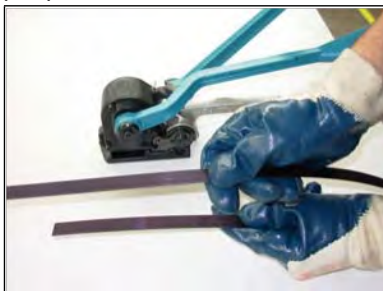

(F2)



(F3)



Release the levers (pic.F4) Hold the sealing lever with your left hand and with right hand move the tension lever forwards and backwards until the required strap tension is obtained (pic.F5) . Move the sealing lever forward; keep the right hand on the tensioning lever to resist the opposing force (pic.F6-F7). The strap is sealed and cut. Return the sealing lever, squeeze the opening and sealing lever together to open the tool and turn it to right side to release from strap (pic.F8-F9) .

(F4)



(F5)



(F6)



(F7)



(F8)



(F9)



Seal check (pic.G1-G2-G3): A regular seal quality control is very important and it can be checked as follows:

- G1)** stamped seal is not deep enough and the upper strap is not cut
- G2)** correct seal, the upper strap must be cut clean and the cutter must not leave scratch on lower strap
- G3)** the stamped seal is too deep and the lower strap is scratched by cutter

(G1)



NO – seal strength insufficient

(G2)



Yes -- right

(G3)



NO – strap strength affected

6) SERVICING - CLEANING

Periodically clean the tool from strap dust, particularly the feed wheel, the gripper plate and the punches using compressed air (not other tools, keys).

Cutter replacement

(L1)



(L2)



(L3)



(L4)



(L5)



Remove the 4 cover screws (pic.L1), slightly move the outside the cover (pic.L2), turn the cover to the left until you see the cutter (pic.L3). Remove and replace the cutter with pliers (pic L4-L5). Reassemble in reverse order.

Feed wheel replacement

(M1)



(M2)



Remove the side strap guide as shown "Strap size conversion", remove the feed wheel from shaft, replace it (pic. M1-M2) and reassemble in reverse order.

Gripper replacement

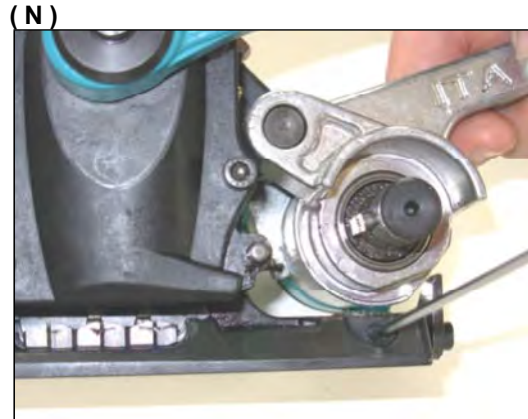

After removing the feed wheel, as shown before, unscrew the gripper screw (pic.N) and replace the gripper. Reassemble all in reverse order.

Lower punch replacement

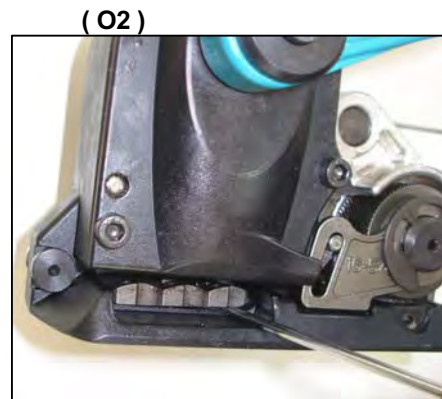

Remove the 2 locking screws (pic.O1), with a screw driver remove the worn out punch from pin, install the new one and tighten the 2 screws.

Upper punches replacement

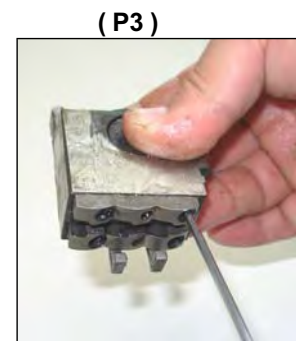
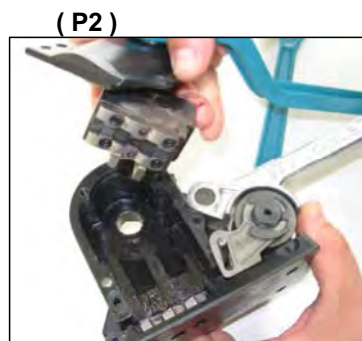

Remove the 4 cover screws and turn cover(pic.P1), remove the whole group (punches holder, cover, lever)(pic. P2), separate the punches holder from other parts, remove the extractors, and unscrew the 4 locking screws to replace the punches.

7) TROUBLESHOOTING

PROBLEM
REMEDY
The feedwheel slides and scratches the strap
Check if the feed wheel is dirty or worn out. Check the gap between the feed wheel and locking bottom plate (right around .008" - .012")
The lower strap isn't locked between bottom plate and feedwheel, the tool goes forward
Check the gap between the feed wheel and bottom plate (right around .008" - .012"). Check if the locking bottom plate is dirty or damaged.
Seizing signs on strap
Check the gap between the feed wheel and locking bottom plate (right around .008" - .012")- try to increase the gap. Check if the strap qualities are right for the tool and application.
The strap is breaking during tension
Too much tension force applied. Check if the strap qualities are right for the tool and application
The sealing isn't in the middle of strap
Check the strap size and adjust the guides - Check the guides alignment
The tensioned strap turns sideways
Too much tension force applied. Check if the strap qualities are right for the strapping tool and application. Check if the locking bottom plate is moving free
The strap is breaking during the sealing
Too much sealing depth. Check that the cutter doesn't cut the lower strap—adjust the sealing depth
The sealing isn't complete – upper strap not cut
Check the strap thickness and try to adjust the sealing / cutting depth Check if the strap qualities are right for the strapping tool. Check if the cutter is damaged
After sealing it is not possible to remove the tool from the strap
Check, if after sealing and cutting the strap the tool is locked—cut the strap from package and use the screw below the opening lever to remove the strap(see "feed wheel gap adjustment") If the upper strap isn't cut and it is not possible to remove the tool, adjust the sealing depth and complete the operation.

8) LAYOUT-SPARE PARTS LIST

Ed. 09/08

GREENBRIDGE PART #	ITEM	DESCRIPTION	QTY		
189759	A000015	CAM SHAFT ASSEMBLED	1		
189737	A000018	OPENING LEVER ASSEMBLED	1		
189738	A000019	MAIN FRAME ASSEMBLED	1		
189739	A000020	SIDE COVER ASSEMBLED	1		
190149	B400062	FREE WHEEL HF 3020	1		
189740	B400063	FREE WHEEL HFL 3030	1		
190148	B400064	ROLLER BEARING HK2220	1		
190032	B500036	SCREW M5X12	4		*
189141	B500040	SCREW M6X16	1		
189138	B500046	SCREW M5X10	2		
189732	B500052	NUT M6 H5 8.8	1		
190161	B500068	SCREW M3X8	2		*
189576	B500071	SCREW M8X6	1		
190034	B500073	NUT M5	1		
189743	B500074	WASHER 6,4X12X1,6 DIN125A	2		
189156	B500139	SCREW M6X20	1		
189744	B500388	SCREW STEI M5X5 UNI5927	1		
190048	B500401	SCREW M5X30	1		
208247	B500462	WASHER R150 DIAM.5	1		
206241	B500463	WASHER	1		
189745	B600065	CIRCLIP RS 15	1		
189746	B600080	KEY A 5X5X12	2		
189689	B600081	KEY A 5X5X18	1		
189747	B600321	GUIDE SOCKET BM 16-15	2		
189130	B700029	PIN 6x12 DIN6325	1		
189750	B700075	PIN 3X10 DIN6325	1		
190062	B700076	PIN 4X12 DIN6325	1		
189801	B700077	PIN 5X10 DIN6325	1		
189735	D001300	SEALING LEVER	1		
189751	D001310	TENSION LEVER	1		
189752	D001330	SEALING LEVER COVER	1		
189656	D001340	OPENING LEVER SHAFT	1		
189753	D001350	SHAFT	1		
189629	D001360	PUSH RING	1		
189688	D001370	EXTRACTOR	2		
190119	D001380	PUNCHES HOLDER	1		
189535	D001390	UPPER RH PUNCH 13-16-19	1		*
189534	D001400	UPPER LF PUNCH 13-16-19	1		*
189754	D001410	LOWER PUNCH 13-16-19	1		*
190122	D001420	SPECIAL SCREW	4		*
189607	D001430	STRAP CUTTER	1	§	*
189755	D001440	FEEDWHEEL SHAFT	1		
189756	D001450	EXTRACTOR RING	1		
189614	D001460	FEEDWHEEL	1	§	*
189653	D001470	LOCK STRAP PIN	1		*
189617	D001480	LOCK STRAP PLATE	1	§	*
189757	D001490	FRONT STRAP GUIDE	1		
189758	D001500	REAR STRAP GUIDE	1		
189654	D001510	OPENING SPRING	1		*

GREENBRIDGE PART #	ITEM	DESCRIPTION	QTY		
189615	D001520	SIDE STRAP GUIDE 19mm - 3/4"	1		
189569	D001530	SIDE STRAP GUIDE 16mm-5/8"	1		
189616	D001540	SIDE STRAP GUIDE 13mm-1/2"	1		
189612	D003320	STRAP GUIDE PIN	1		
189802	D004910	H.T. STRAP CUTTER	1	§	*

	§	WEARING PART
	*	PART THAT SHOULD BE STOCKED

CE DECLARATION OF CONFORMITY

GREENBRIDGE declares under own responsibility that the under mentioned machinery, to which this declarations refers, is in conformity with **2006/42/CE** Directive and successive modifications, as well as with standards **EN12100-1 / EN12100-2**.

MODEL
SM3000



MACHINE TYPE:

MANUAL SEALLESS STRAPPING TOOL STEEL STRAP

GREENBRIDGE

6277 Heisley Road Mentor, Ohio 44060
Tel. 440-357-1500 Fax 440-352-9553 www.greenbridge.com

Manufactured in Italy