



PHT801/1201

OPERATION MANUAL | SPARE PARTS LIST

PNEUMATIC PLASTIC STRAPPING TOOL



CE

READ ALL INSTRUCTIONS BEFORE OPERATING THE TOOL

GREENBRIDGE

6277 HEISLEY ROAD, MENTOR, OHIO 44060

PHONE: 440.357.1500, FAX: 440.352.9553

WWW.GREENBRIDGE.COM

ED. 4/21

TABLE OF CONTENTS

- 1) Safety instructions
- 2) Technical data
- 3) Warranty and liability
- 4) Installation
- 5) Operating elements / adjustments
- 6) Operation
- 7) Servicing and cleaning
- 8) Troubleshooting
- 9) Layout – spare parts list

1.) SAFETY INSTRUCTIONS



READ THE OPERATING INSTRUCTIONS CAREFULLY



WEAR EYE, FACE, AND HAND PROTECTION WHEN OPERATING THE TOOL.



GENERAL SAFETY INSTRUCTIONS:

The tool must be used by properly trained people. Failure to follow the operating instructions or improper use could cause strap breakage, injuries, or package damages.

Check tool daily, do not use tool with worn or damaged parts. Use original spare parts for replacement. Never modify any tool part.

Do not put fingers, hands or other body parts between the strap and package during the cycle.

It is your responsibility to check the seal joints made by your tool. Training about the weld time adjustment will be useful to check the seal quality in order to avoid severe injury. Never move goods with bad quality seals. Only use specific strap dispenser to dispense the strap. Keep your working area clean and always use the tool in good balance and safety conditions. Never use straps as a means of pulling or lifting goods.

Always use a proper safety strap cutter and keep other people and yourself at a safe distance from strap, always stand to side of strap, away from direction of strap trajectory once cut. Hold the upper strap portion and pay attention that the lower strap will snap forward away from you.

Improper operation, excessive tensioning, use of non-recommended strap, or sharp corners on the package could cause a loss of strap tension and/or strap breakage that could lead to packaging failure or injury. The following is recommended; use edge protectors if package has sharp corners, place the strap correctly around a properly positioned package, stand in safety position (on one side of strap) during strapping cycle, and use the correct strap quality, width, thickness, and break strength as recommended in this manual.

Please save this manual, as it is a part of the tool. This tool is manufactured without any substances which could be dangerous to health. National instructions must be observed for disposal of all the parts.



GENERAL SAFETY INSTRUCTIONS FOR COMPRESSED AIR:

Never operate this tool using a bottled air or other gas source. Do not exceed the air pressure range as shown in this operation manual. For all adjustments, repairs or cleaning of the tool, always disconnect air supply. Always use dry, clean and lubricated compressed air.

2.) TECHNICAL DATA

DESCRIPTION OF THE TOOL: The tool model PHT801/1201 is designed to strap packages with plastic strap. The strap is fed around the package manually and inserted in the tool, tensioned, cut and friction welded by the tool.

TOOL SIZE		
Length:		300mm – 11.8”
Width:		150mm – 6”
Height:		175mm – 6.9”
Weight:		5.1 kgs – 11.2lbs

AIR REQUIREMENT		
Pressure range:		4.5-7 bar / 64-99 psi
Air consumption:		14 L/s – 29cuft/min

SPECIFICATIONS		
Max.Tension force:		3500N PHT801 6.5 bar – 2 psi 5000N PHT1201 6.5 bar – 2 psi
Tensioning speed:		9 mt/min PHT801 6 mt/min PHT1201
Sealing:		Friction weld seal
Joint strength:		80% plastic strap strength*
Level sound emission. Measurement type A (2003/10/CE)		77 dB (A)
Vibrations at handle (2002/44/CE)		<2.5 ms ²

- Depends on kind of strap

CHART OF TYPES

ITEM	MODEL	STRAP	THICKNESS
T111323	PHT801 -1/2” *	PET -1/2”	>0.028” – 0.055”<
T119923	PHT801 – 5/8” - 3/4”	PP-PET -5/8”-3/4”	>0.028” – 0.047”<
T129933	PHT1201 – 5/8” - 3/4”	PET - 5/8”-3/4”	> 0.040” – 0.055”<

* Only with clutch on tensioning

3.) WARRANTY

Greenbridge warrants all its tools and battery chargers during a period of 6 months from the shipping date document. Wear parts are warranted for 45 days, otherwise wear parts are excluded from regular warranty, wear parts are shown on spare parts list (in tool manual).

Warranty includes free replacement parts. The warranty is not valid in case of improper use, lack of maintenance, tampering, arbitrary modifications and reparations, use of non-original parts, disregard of instructions of the operation manual, or missing serial number. No compensation can be claimed for production shutdowns and for damages to people and objects due to tool defects. Greenbridge reserves the right to modify the tools and documentation without any obligation to update previous ones.

Greenbridge warrants all its batteries during a period of 120 days from the shipping date document. The manufacturer is committed to replace it with a free battery only when there are manufacturing defects that make it unfit for use.

4.) INSTALLATION

It is recommended to use always a dryer unit near the compressor and a filter-regulator-lubricator unit with pressure gauge close to tool air connection to avoid the entrance of water and dirt in the valves or in the pneumatic motors. Check daily the presence of oil in the lubricator. Connect the tool to air with quick connector $\frac{1}{4}$ " and use minimum 8mm or $\frac{3}{8}$ " internal diameter pipe; max length for flexible pipe 10 m between tool and regulator group. Check that your compressor / air distribution plant is able to supply the right air quantity as shown in the operation manual without losing pressure.

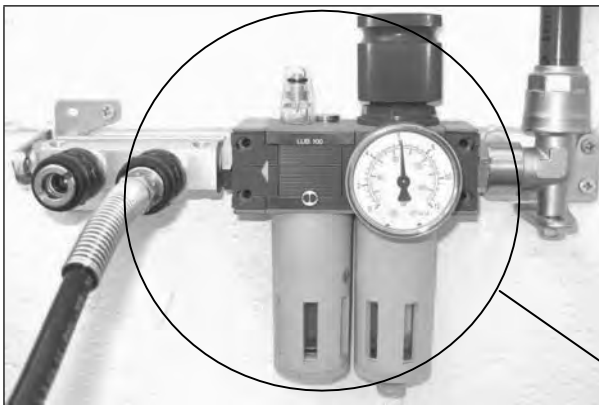

S100001



TOOL AIR CONNECTION

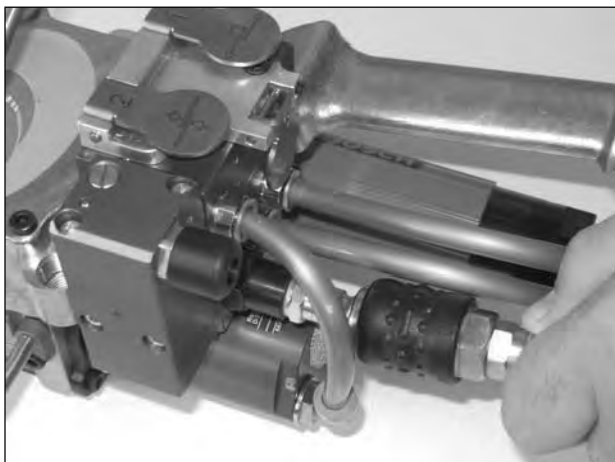

5.) OPERATING ELEMENTS AND ADJUSTMENTS

DO NOT OPERATE THE TOOL WITHOUT STRAP, YOU COULD DAMAGE THE FEEDWHEEL AND THE WELDING / CUTTING GROUP

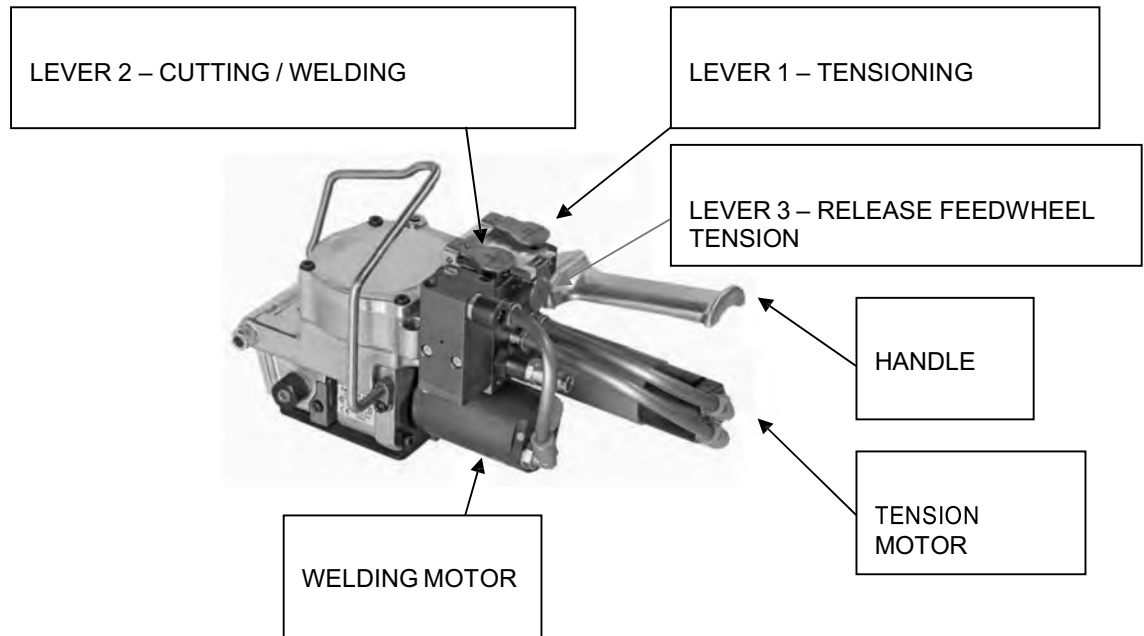

Adjustment of welding - cutting time

The welding time can be adjusted with a screwdriver (pic.A). Depending on strap quality and dimensions, turning the screw, as shown; turning clockwise will increase the time, turning counter clockwise will decrease the time.

Adjusting strap tension

The maximum strap tension can be adjusted with a screwdriver by turning the screw on the pneumatic motor as shown (pic.B). Turning clockwise will reduce the tension, turning counter clockwise will increase tension. Do not exceed maximum tension.

Adjusting strap tension by clutch (optional)

The maximum strap tension could be adjusted also with clutch system (optional). Turning the nut clockwise will increase tension and turning it counter clockwise will reduce tension.

(A)

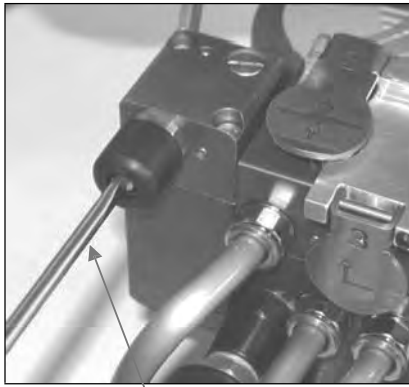

Welding time adjustment

(B)



Tension motor adjustment force

(C)

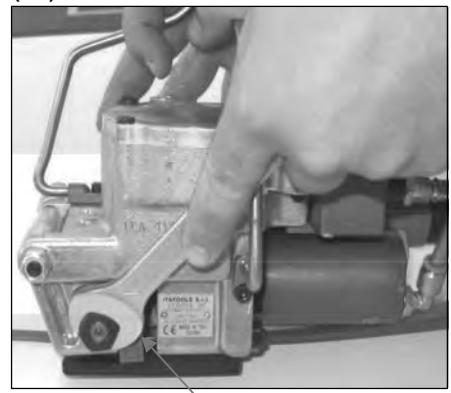

Clutch adjustment

Feed wheel gap adjustment

(D1)

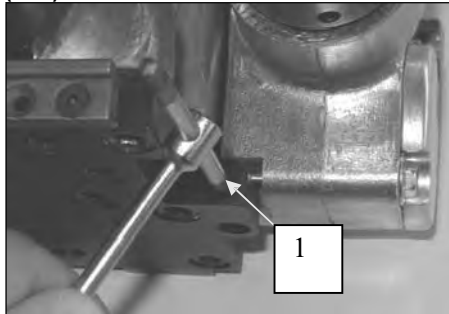

(D2)

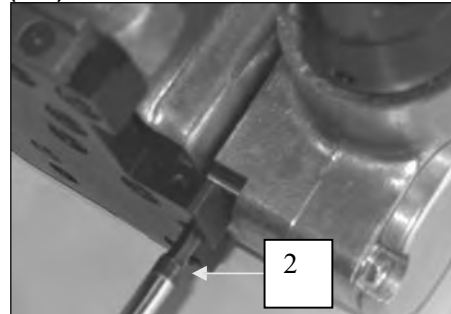

(D3)

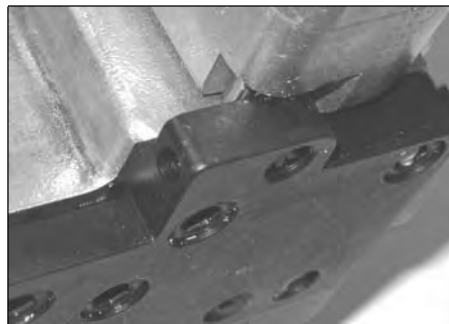

(D4)

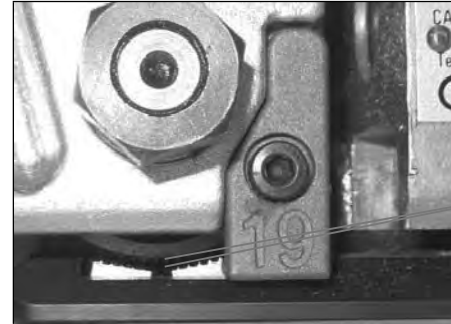

0.2mm
0.008"

It is possible to adjust the gap between feed wheel and grippers in order to change the pressure on the strap; Loosen the locking screw 1(pic.D1) and turn screw 2 (pic.D2), clockwise the gap will be increased; counter clockwise the gap will be decreased. Screw 2 pushes against the gearbox housing pin (pic. D3). The standard gap is 0.2 mm (0.008") (Pic. D4).

Strap size conversion

(E1)

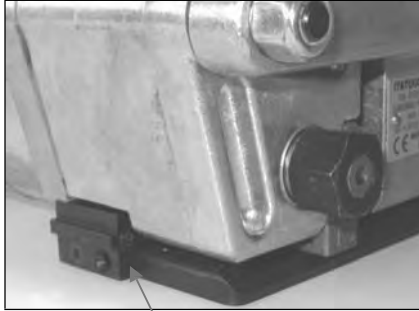

Front strap guide (1)

(E2)

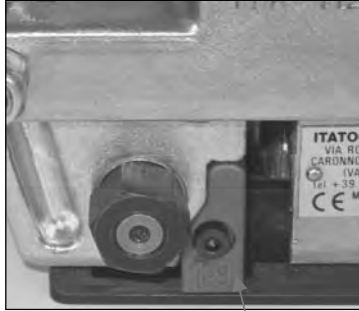

Side strap guide (2)

(E3)

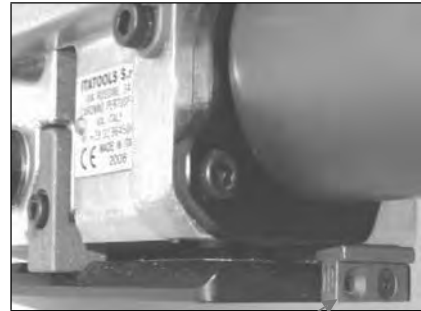

Rear strap guide (3)

To set the tool for 13mm ($\frac{1}{2}$ ") (Only for PHT801 tool) - 16mm ($\frac{5}{8}$ ") - 19mm ($\frac{3}{4}$ ") strap sizes follow the below instructions:

<p>19 > 16 $\frac{3}{4}$" > $\frac{5}{8}$"</p>	<p>Turn strap guides 1 and 3 in 16mm($\frac{5}{8}$") position (pic.E1-E3)- Replace strap guide 2 with 16mm ($\frac{5}{8}$") part (pic.E2)</p>
<p>16 > 19 $\frac{5}{8}$" > $\frac{3}{4}$"</p>	<p>Turn strap guides 1 and 3 in 19mm($\frac{3}{4}$") position (pic.E1-E3)- Replace strap guide 2 with 19mm ($\frac{3}{4}$") part (pic.E2)</p>
<p>16/19 > 13 $\frac{5}{8}$" - $\frac{3}{4}$" > $\frac{1}{2}$"</p>	<p>Replace strap guides 1 and 3 with 10/13 part and put in 13mm($\frac{1}{2}$") position (pic.E1-E3)- Replace the strap guide 2 with 13mm ($\frac{1}{2}$") part (pic.E2)</p>
<p>13 > 16/19 $\frac{1}{2}$" > $\frac{5}{8}$" - $\frac{3}{4}$"</p>	<p>Replace strap guides 1 and 3 with 16/19 part and put in required position (pic.E1-E3)- Replace the strap guide 2 with required size (pic.E2)</p>

6.) OPERATION

Wrap the parcel to be bound with the strap, as showed in pic.F1, hold the end of the strap with left hand and overlap the strap with right hand (beware that the strap must be clean, oil and grease free); open the tool squeezing the handle and motor together with right hand, then insert the two straps between the body and bottom plate pushing the straps against the front and rear guides (pic.F2). Release handle (pic.F3).

(F1)

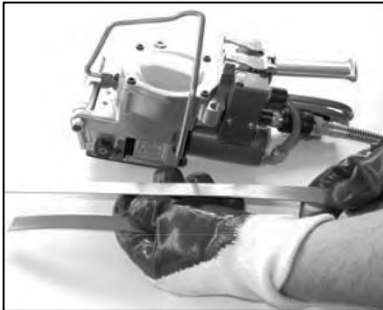

(F2)



(F3)

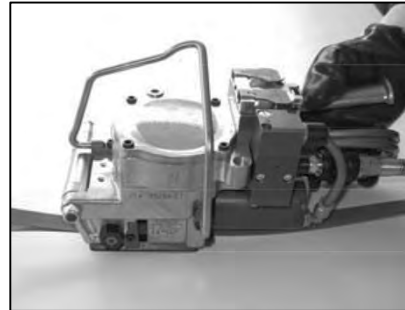

Push the tension lever #1(pic. F4) until desired tension is reached or until the motor stalls. Release lever #1 and push lever #2 one time (pic. F5) to cut and weld the strap. (Adjust time before sealing).Welding and cooling time will be signaled by the little piston (pic. F6) when piston returns the welding cycle is complete (pic.F7). At this point you can remove the strap by following the instructions below.

(F4)

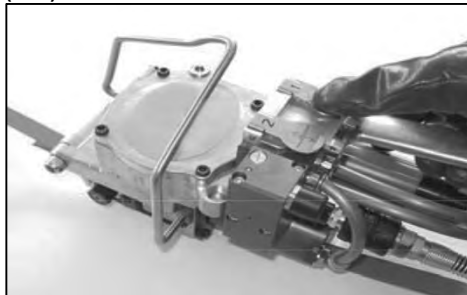

(F5)

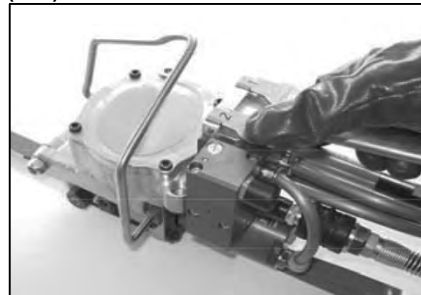

(F6)



(F7)



WARNING : Wait until the piston returns (pic.F7) before releasing the strap

Push lever #3 for around one second to release the feed wheel tension force (pic. F8), open the tool by squeezing the handle and motor together and then remove the tool by pulling it to the right (pic. F8).

(F8)



(F9)

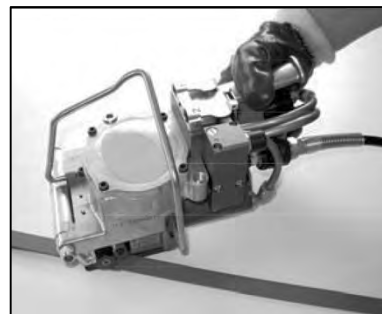

Seal check

A regular seal check is very important and it can be visually examined as follows:

G1) -short sealing time-

G2)- right sealing time-

G3) -too long sealing time-

(G1)

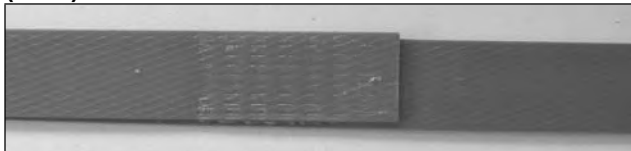

NO – seal strength insufficient

(G2)

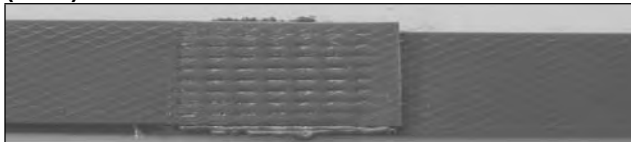

YES -- right

(G3)

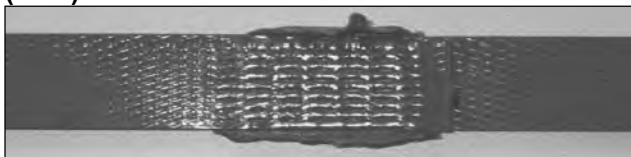

NO – seal strength affected

7.) SERVICING - CLEANING

DISCONNECT TOOL FROM COMPRESSED AIR LINE BEFORE ANY SERVICE OR CLEANING

Periodically clean the tool from strap dust, particularly the feed wheel, the gripper plates and the cutter. Use compressed air or a wire brush (do not use other tools or keys) (pic. H1,H2)

(H1)

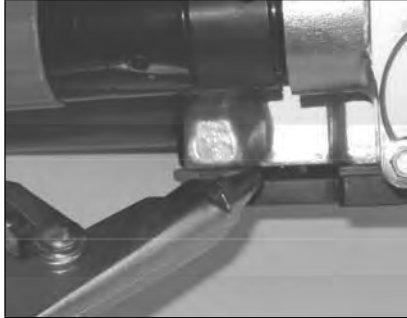

(H2)

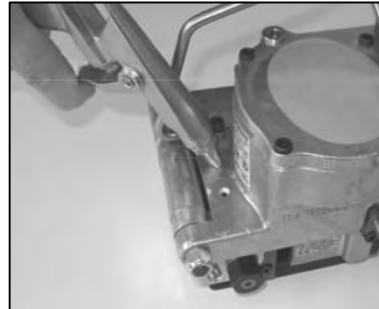

Cutter replacement

Disconnect the air pipe from welding motor (pic.L1), remove the 2 locking motor screws (pic.L2), remove the motor (pic.L3). Remove the cutter spring with pliers (pic.L4), put air in the disconnected pipe to push down the piston to free up the cutter and then remove the cutter from its seat by using pliers (pic.L5). Replace it and reassemble in reverse order putting grease on spring and cutter seat.

(L1)



(L2)



(L3)



(L4)

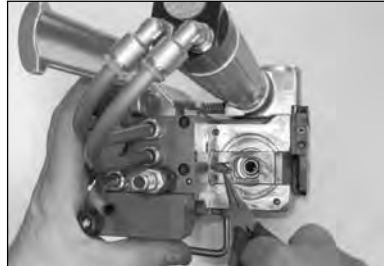

(L5)



Feed wheel replacement

Remove the pushing spring (pic.M1), disconnect the motor pipes (pic.M2), remove the 6 bottom plate screws (pic.M3), unscrew the holding screw (pic.M4), remove the nut on the pivot shaft (pic.M5) and remove the shaft from main frame (pay attention to the shim) (pic M6). Remove the feed wheel shaft nut (pic.M7) Remove the front cover, bushing, spacers, and feed wheel (pic. M8); replace the worn part (pic. M9). Reassemble in the opposite order by starting with the feed wheel shaft parts.

(M1)



(M2)



(M3)



(M4)

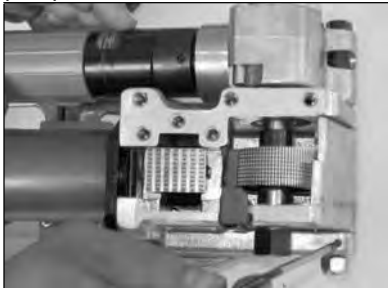

(M5)



(M6)

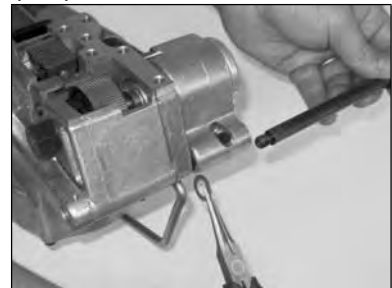

(M7)



(M8)

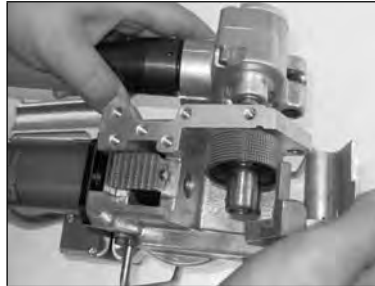

(M9)

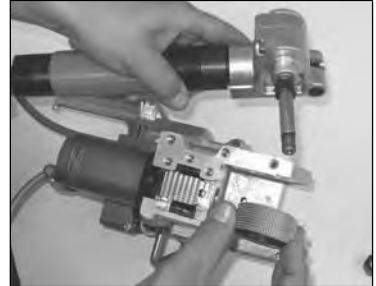

Bottom plate grippers replacement

(N1)



(N2)



(N3)

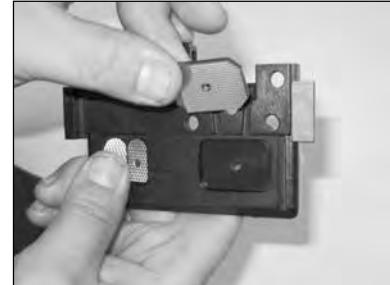

Remove the 6 bottom plate screws (pic.N1), unscrew the gripper screws (pic.N2), replace the parts (pic.N3), and reassemble in opposite order.

Welding gripper replacement

Remove the cutter as shown in L1 to L5 sequence; remove the bottom plate as Pic. N1, remove the safety circlip from welding gripper pin (pic.O1), remove the pin from welding gripper (pic.O2), and remove welding gripper (pic. O3) and replace the worn part. Reassemble all parts in reverse order. It is advised to replace the safety circlip with a new one.

(O1)

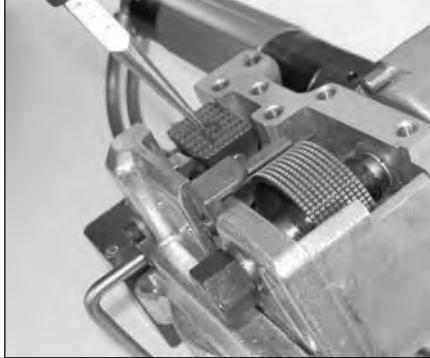

(O2)

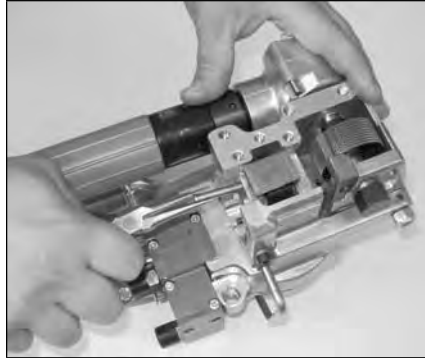

(O3)

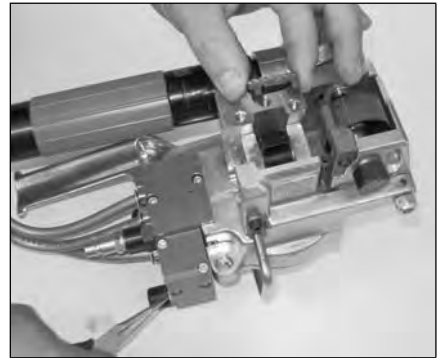

8.) TROUBLESHOOTING

PROBLEM
REMEDY
The tension of strap is insufficient
Check: air pressure value (min.4.5 bar), if the filter / lubricator and/or the pneumatic motor is damaged or dirty (contact the after sale service), the power adjusting screw on the pneumatic motor, the pneumatic circuit, tension button, connections, pipes, valve (contact the after sale service) Check if the clutch is loose (only for clutch models)
The feed wheel slips and mills on strap
Check if the feed wheel and grippers are dirty or damaged, check the gap between feed wheel and grippers (around 0,2mm– 0.008”). Adjust the motor power—too much tension force. Check if the strap qualities are right for the strapping tool and application
The strap is breaking during tension
Adjust the motor power—too much tension force. Check if the strap qualities are right for the strapping tool and application. Check for sharp edges on package.
The tensioned strap is sideways; the seal isn't in the middle of strap width
Adjust the motor power—too much tension force. Check if the strap qualities are right for the strapping tool and application. Check that the strap guides are set for the proper width and are aligned right.
The lower strap isn't locked between the grippers and feed wheel so the tool goes forward during the tension
Check the gap between feed wheel and grippers (around 0,2mm– 0.008”). Check if the locking strap plates are dirty or damaged. Adjust the motor power for quality of strap
Top strap is dragging on lower strap
Check the gap between feed wheel and grippers (around 0,2mm– 0.008”) - try to increase the gap. Check if the strap qualities are right for the strapping tool and application.

Tensioning problem— the tool comes back after tensioning
Probably damage to the “holding tension system” (contact the after sale service)
Air leak
Check hose connections and fittings (contact the after sale service)
Seal time is too short; The upper strap isn't completely cut; the cutting is inconsistent
Improper weld time. Check if the sealing foot or the cutter are damaged or worn out. Check: if the sealing foot is dirty or slides on strap, if the tool returns after tensioning. Check the air pressure value. Check if the strap qualities are right for the strapping tool and application. Check, if the sealing motor is locked or dirty. Check that the air circuit has the proper requirements. The cutter spring is wrong for the strap or is damaged, try to replace it: - 400-0034 medium -- 400-0149 strong
Seal time is too long; the strap is breaking during the seal – cut
Improper weld time adjustment, may be too long, adjust it.
Both straps are cut during sealing
Check if the gripper plate (under the sealing foot) is dirty or damaged (clean or replace it) Check if there is too much tension. Improper weld time adjustment, may be too long, adjust it.
After sealing, pushing the lever 3, the tension motor doesn't turn and the strap isn't released
The “holding tension system ”is faulty (contact the after sale service) Check the pneumatic valve and air circuit and if the pneumatic motor is damaged or dirty (contact the after sale service). Do not use tools to remove the strap from the strapping tool. Cut the strap from the package and then remove the bottom plate from the tool to release the strap.
After the cycle is not possible remove the tool from package
Check if the sealing piston is locked in lower position (down), in this case cut the strap from the package and find out the problem (could be a pneumatic valve problem)
The sealing time will not remain constant
Timer valve problem, try to clean, lubricate or replace it (contact the after sale service)

9.) LAYOUT-SPARE PARTS LIST

Ed. 06/17

GREENBRIDGE PART #	ITEM	DESCRIPTION	QTY		
189604	A000014	ASSEMBLED GEARBOX BODY	1		
189571	A000034	TENSION MOTOR ASSEMBLED MT	1		
189572	A000035	TENSION MOTOR ASSEMBLED HT	1		
189570	A000086	ASSEMBLED FRONT COVER	1		
189808	A000131	PHT 1401 TENSION MOTOR	1		
186897	B100032	PIPE 6x8 (Length meters)	0,5		*
189137	B100310	SWING ELBOW RL31 8 1/4	1		*
189502	B100311	SWING ELBOW RL31 8 - 1/8	2		*
189105	B200309	FAST AIR MALE CONN.	1		
189479	B200347	PNEUM. VALVE	1		*
189120	B300020	GASKET 1.5X6.1 IN MTS	0,11		
189177	B300021	O-RING 2125 (D32)	1		
189471	B300022	O-RING 3300 (D85)	1		
189911	B300446	O-RING2025/105	1		
189508	B300451	O-RING 4300 N	2		
189180	B400001	ROLLER BEARING BK0810	1		
189182	B400002	BEARING 7200BE 2RS	1		
189146	B400003	ROLLER BEARING HK0808	2		
189176	B400004	BEARING 6001 2Z	2		
189149	B400005	ROLLER BEARING NK1616	1		
189198	B400008	BEARING 6001 2RS	1		
189166	B400009	RING IR 12x16x16	1		
189573	B400339	RING IR 12x16x20	1		
189574	B400340	AXK1226 SKF	1		
189575	B400341	AS 1226 SKF	2		
190031	B500035	SCREW M4X10	1		
190196	B500037	SCREW M4X8	1		
189136	B500039	SCREW UNC 10X1/2"	9		*
189179	B500043	HEX HEAD SCREW W/FLANGE M5X12	2		
189480	B500044	SCREW M4X45	3		
189276	B500045	SCREW M4X5	2		
189698	B500047	SCREW M5X8	2		
189438	B500048	SCREW M4X6	3		*
189163	B500053	LOCK WASHER	1		
190161	B500068	SCREW TCEI M3X8 UNI5931	3		
189576	B500071	SCREW STEI M8X6	1		
189783	B500407	SCREW UNC 1/4X1/2 ANSI B18.3	1		
190147	B500211	LOCK WASHER	2		
190044	B500379	SCREW STEI M4X5 UNI5923	1		
189761	B500386	SCREW M4X30 DIN7984	2		
189785	B500407	SCREW UNC 1/4X1/2 ANSI B18.3	1		
189982	B500456	SCREW 10-24X5/8"	1		
189578	B500394	SCREW M6X14	1		*
189192	B600011	WASHER PS 10x16x0.5	1		
189183	B600012	CIRCLIP A10 DIN471	1		
189153	B600013	CIRCLIP H5	1		*
189193	B600014	WASHER PS 22x30x0,1	VAR		
189194	B600015	WASHER PS 22x30x0,5	1		
189279	B600016	WASHER PS 10x16x1	1		
189506	B600017	WASHER PS 22x30x1,5	1		
189476	B600028	SPRING R10-051 ISO 10243	1		*
189170	B600059	CUP WASH. 25x12.2x1.5	3		

GREENBRIDGE PART #	ITEM	DESCRIPTION	QTY		
189506	B600017	WASHER PS 22X30X1,5	1		
189476	B600028	SPRING R10-051 IOS 10243	1		
189170	B600059	CUP WAS 25X12.2X1.5	1		
189579	B600338	GUIDE SOCKET BM 12 14 25	1		
189580	B600342	GUIDE SOCKET BM 16 18 10	1		
189767	B600389	WASHER PS 22x30x0,2	VAR		
189500	B700030	PIN 3x24 DIN6325	1		
189501	B700031	PIN 3x60 DIN6325	1		
189581	B700078	PIN 6X18DIN6325	1		
189668	B700427	ELASTIC PIN 5X16 UNI6874	1		
189134	B900348	PNEUMATIC MOTOR 0607951449	1		
190117	D000280	CUTTER SPRING ITA - 13mm	1		
189132	D000620	MEDIUM CUTTER SPRING	1		*
189157	D000780	LOCKING STRAP PLATE	1	§	*
189151	D001250	WELDING FOOT PHT801 1/2"	1	§	*
189133	D001260	CUTTER	1	§	*
189282	D001620	CONNECTING ROD PIN	1		
189150	D001630	CONNECTING ROD	1		
189482	D001640	ECCENTRIC SHAFT	1		
189152	D001650	WELDING FOOT PIN	1		
189478	D001670	OPENING LEVER	1		
189121	D001710	PISTON SPRING	1		
189232	D001720	STRONG CUTTER SPRING	1		*
189178	D001730	GEARBOX COVER	1		
189484	D001740	CROWN	1		
189181	D001750	WORMGEAR	1		
189174	D001760	FEEDWHEEL SHAFT	1		
189190	D001780	SPECIAL NUT	1		
189585	D001790	FEEDWHEEL	1	§	*
189586	D001800	REAR STRAP GUIDE 5/8" - 3/4"	1		
189587	D001810	SIDE STRAP GUIDE 5/8"	1		
189588	D001820	SIDE STRAP GUIDE 3/4"	1		
189589	D001830	TENSION START LEVER	1		
189590	D001840	WELDING START LEVER	1		
189591	D001850	REVERSE START LEVER	1		
189762	D001860	LEVERS SUPPORT	1		
189592	D001870	SUSPENSION HOOK	1		
189143	D001880	SIDE SUSPENSION HOOK SUPPORT	1		
189140	D001890	UPPER SUSP. HOOK SUPPORT	1		
189593	D001900	FEEDWHEEL WASHER	1		
189594	D001910	SPRING PIN	1		
189595	D001920	REAR STRAP GUIDE 1/2"	1		
189596	D001930	SIDE STRAP GUIDE 1/2"	1		
189490	D001950	AIR CONNECTION	2		
189763	D001960	REAR FRICTION PLATE	1		
189168	D001970	FRICTION PLATE (CLUTCH ONLY)	2	§	*
189169	D001980	FEEDWHEEL FOR CLUTCH SYSTEM	1	§	*
189167	D001990	FRONT FRICTION PLATE	1		

GREENBRIDGE	ITEM	DESCRIPTION	QTY		
189597	D003970	FRONT STRAP GUIDE 1/2"	1		
189598	D003980	FRONT STRAP GUIDE 5/8" - 3/4"	1		
189764	D004570	WELDING FOOT 5/8" - 3/4"	1	§	*
189765	D004850	CUTTER PIN	1		
189812	D005020	PISTON COVER	1		
189813	D005080	PISTON	1		
189814	D005100	SHAFT	1		
189507	D005280	OPENING SPRING PLUG	1		
190010	D005740	BOTTOM PLATE			
190012	D005920	LOCKING TRAP PLATE	1		
	D009470	MAIN FRAME	1		

PHT801/1201

- LOCTITE 243
- LOCTITE 542
- ⚙️ RHODIA "RSIL PATE 4"
- ⚙️ ROYAL PURPLE "NLGI 0"
- ⚙️ ROYAL PURPLE "NLGI 2"
- ⚙️ SKF "LGMT 2"
- ✖️ NON FORNIBILE SINGOLARMENTE
- ✖️ NOT SUPPLIED ALONE

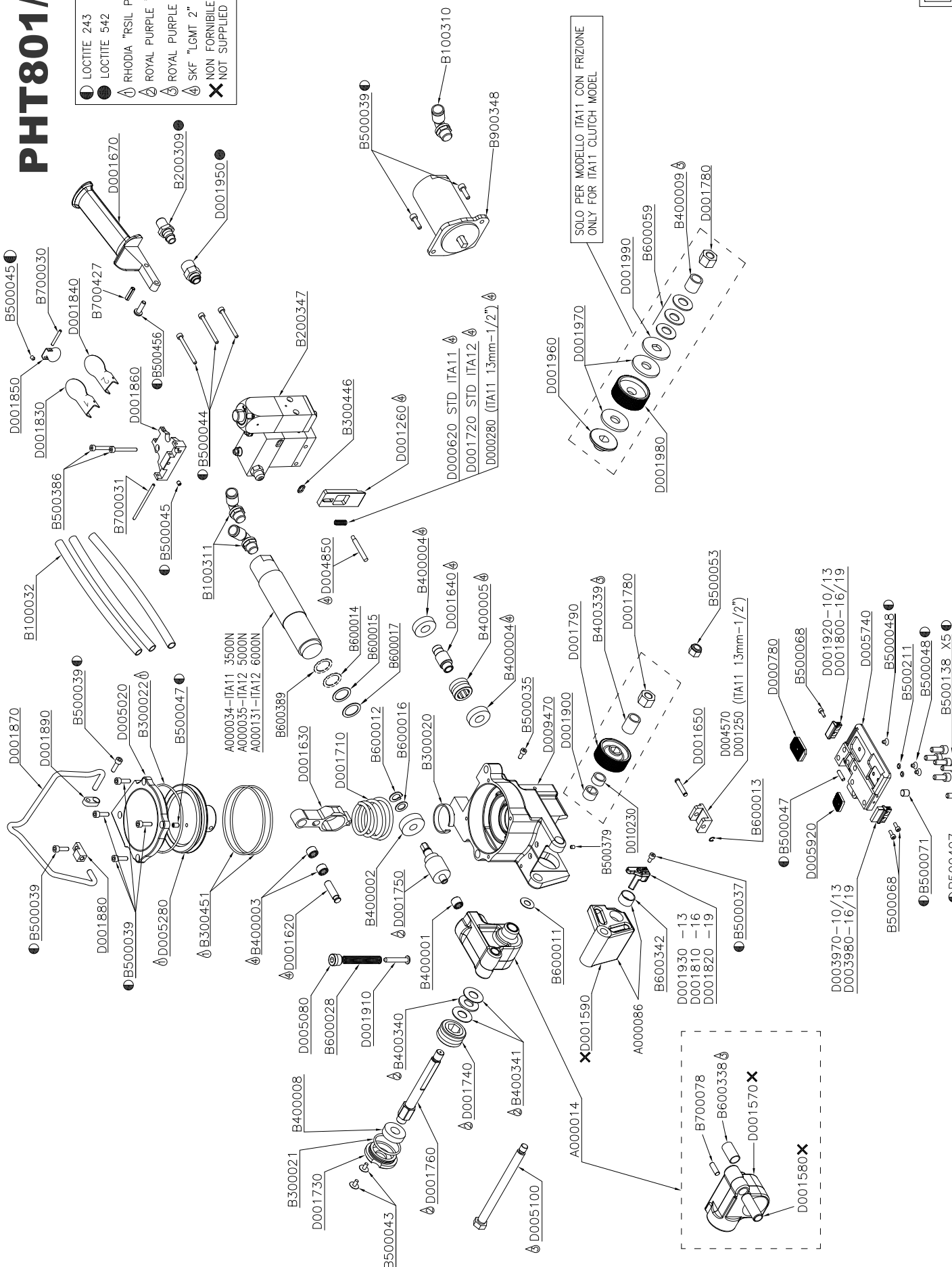

SOLO PER MODELLO ITA11 CON FRIZIONE
ONLY FOR ITA11 CLUTCH MODEL

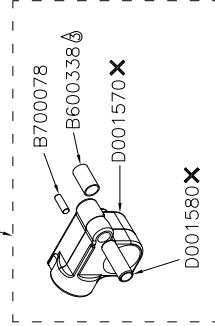

BOSCH 0 607 951 449 – ITEM B900348
400-0036

WELDING MOTOR

0 607 951 449
Issue | 06-04-27
Stand |

Fig./Abb. 1

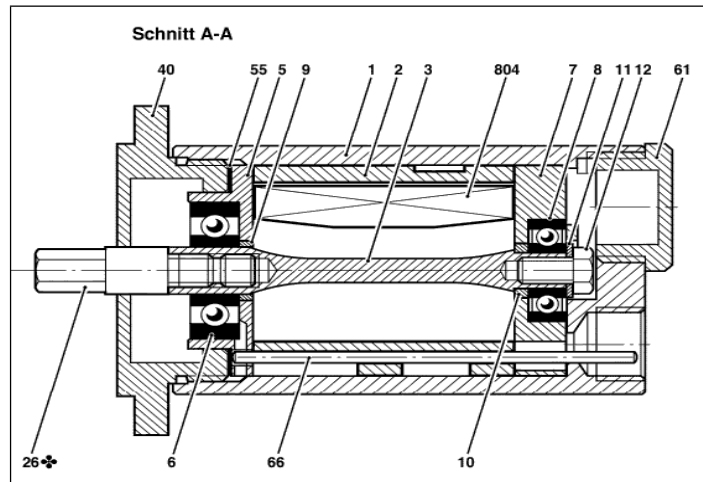
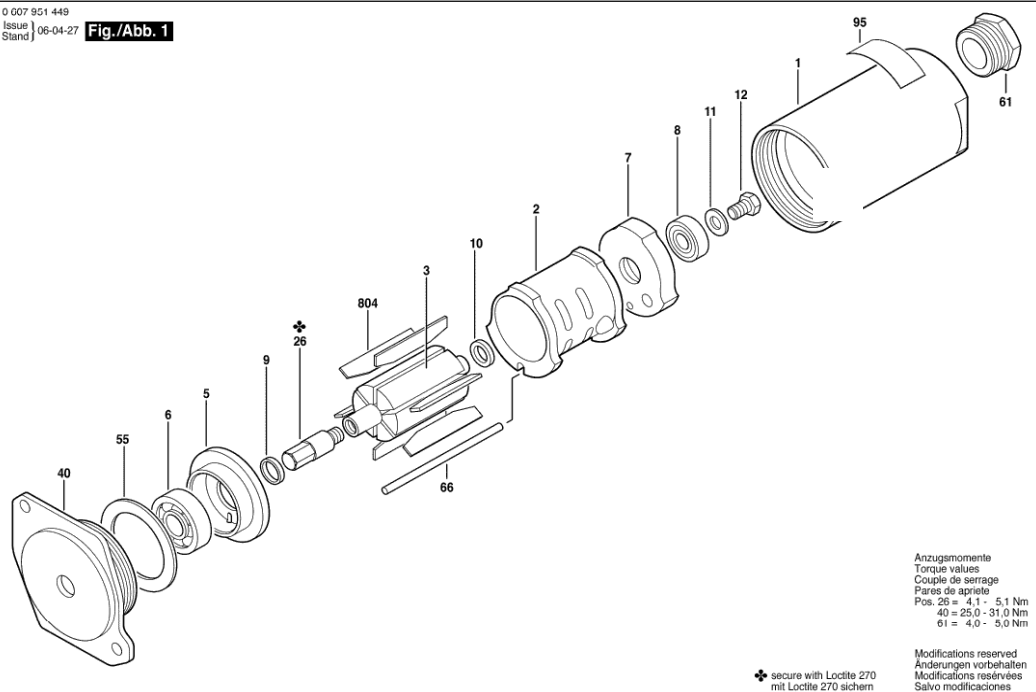

No.	QTY	CODE	DESCRIPTION	JDE PART #
1	1	3 605 125 063	MOTOR HOUSING	X
2	1	3 604 090 009	STATOR / 550W	X
3	1	3 604 220 005	ROTOR	189222
5	1	3 605 700 167	BEARING FLANGE	X
6	1	1 900 905 127	DEEP-GROOVE BALL BEARING / 6000-2Z/C3 DIN 625	X
7	1	3 605 700 010	BEARING FLANGE	X
8	1	1 900 905 029	DEEP-GROOVE BALL BEARING / DIN 625-608-2Z-C3	X
9	1	2 600 200 007	SPACER RING	X
10	1	3 600 202 004	SPACER RING	190193
11	1	2 916 011 012	PLAIN WASHER / DIN 125-A5,3-ST	190192
12	1	2 911 061 150	HEX SCREW / DIN 933-M5x8-8.8	X
26	1	3 606 337 209	CARRIER	X
40	1	3 600 390 040	FLANGE	189697
55	2	3 600 100 048	SEALING DISC	190003
61	1	3 603 462 017	SILENCER	189272
66	1	3 604 710 032	STRAIGHT PIN	X
95	1	3 601 106 047	NAMEPLATE	X
99	1	3 601 119 236	REFERENCE PLATE	X
804	1	3 607 030 260	ASSEMBLY OF SERVICE PARTS / 5 PIECE	X

BOSCH 0 607 951 450 – ITEM A000035
401-0005
TENSION MOTOR
PHT1201

0 607 951 440
 Issue | 04-08-12
 Stand |

Fig./Abb. 1

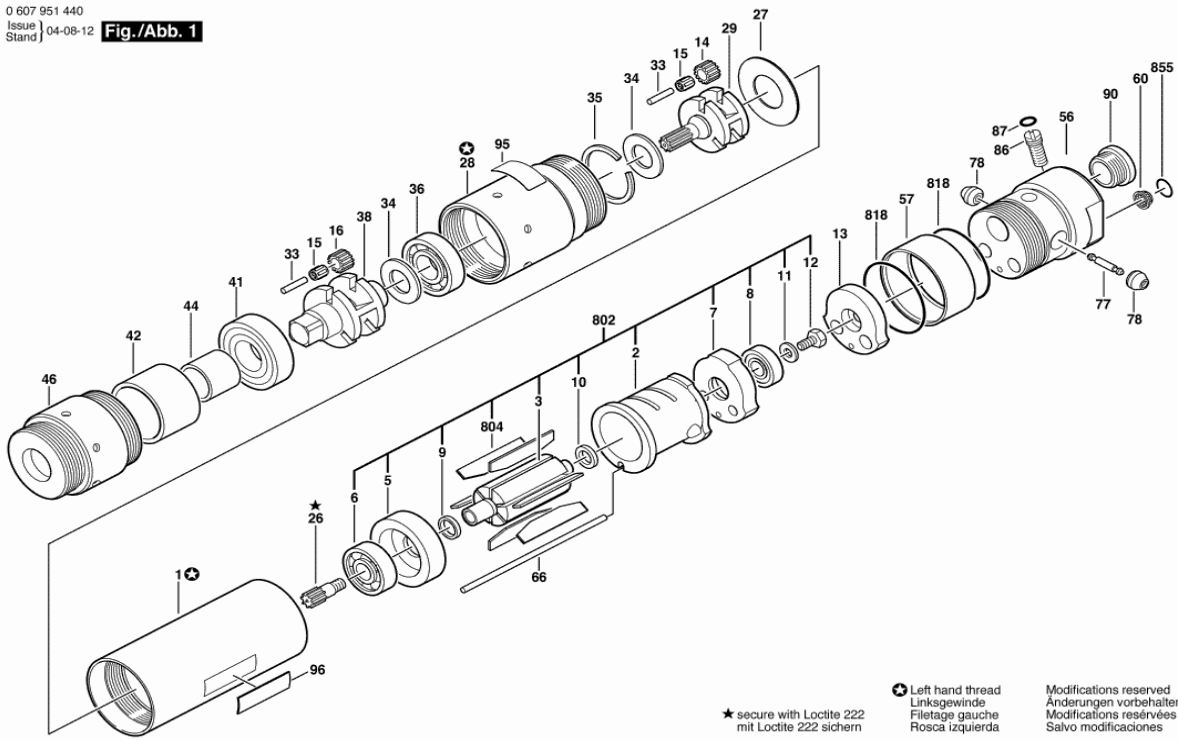

★ secure with Loctite 222
 mit Loctite 222 sichern

⊖ Left hand thread
 Linksgewinde
 Filetage gauche
 Rosca izquierda

Modifications reserved
 Änderungen vorbehalten
 Modifications réservées
 Salvo modificaciones

0 607 951 440
 Issue | 04-08-12
 Stand |

Fig./Abb. S

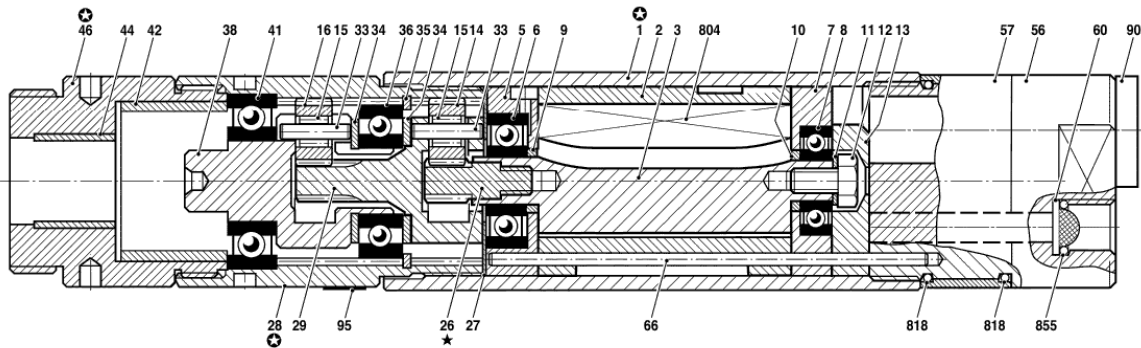

Torque values
 Anzugsmomente
 Couple de serrage
 Pares de apriete
 Pos. 12 = 3,0 - 3,5 Nm
 26 = 4,0 - 5,0 Nm
 28 = 40,0 - 48,0 Nm
 46 = 10,0 - 12,0 Nm
 56 = 15,0 - 18,0 Nm
 60 = 4,0 - 5,0 Nm
 62 = 8,0 - 10,0 Nm

★ secure with Loctite 222
 mit Loctite 222 sichern

⊖ Left hand thread
 Linksgewinde
 Filetage gauche
 Rosca izquierda

Modifications reserved
 Änderungen vorbehalten
 Modifications réservées
 Salvo modificaciones

Dimensions in mm
 Maße in mm
 Cotes en mm
 Medidas en mm

Play between pos. 3 and pos. 5
 Spiel zwischen Pos. 3 und Pos. 5
 = 0,08 - 0,12

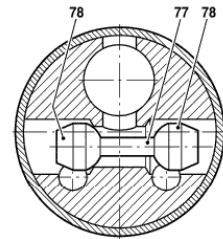
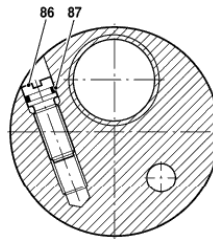
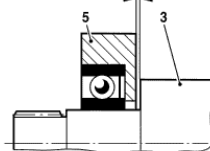

SPARE PARTS LIST A000035 (401-

Nr.	CODE	QTY	DESCRIPTION	JDE PART #
1	3 600 760 114	1	MOTOR HOUSING / BLUE	189730
2	3 604 090 002	1	STATOR / 370W	X
3	3 604 220 025	1	ROTOR	206631
5	3 605 700 005	1	BEARING FLANGE	189728
6	3 600 905 039	1	DEEP-GROOVE BALL BEARING /	190004
7	3 605 700 006	1	BEARING FLANGE	205673
8	3 600 905 148	1	DEEP-GROOVE BALL BEARING / DIN	190005
9	2 600 202 013	1	SPACER RING	206629
10	2 600 202 014	1	SPACER RING	206630
11	2 916 011 012	1	PLAIN WASHER / DIN 125-A5,3-ST	190192
12	2 911 061 150	1	HEX SCREW / DIN 933-M5x8-8.8	X
13	3 602 305 000	1	INTERMEDIATE PIECE	X
14	3 606 316 003	3	CYLINDRICAL GEAR / Z=19	190182
15	3 600 913 000	6	NEEDLE-ROLLER ASSEMBLY / INA	189781
16	3 606 316 002	3	CYLINDRICAL GEAR / Z=18	190182
26	3 606 300 005	1	PINION	X
27	3 600 101 001	1	STOP DISC	X
28	3 606 334 000	1	RING GEAR / Z=49	207204
29	3 606 337 004	1	PLANETARY-GEAR CARRIER	X
33	3 603 201 000	6	NEEDLE ROLLER	205974
34	3 600 103 002	2	SHIM RING	206197
35	3 600 224 000	1	RETAINING RING	X
36	1 900 900 287	1	DEEP-GROOVE BALL BEARING / 6001	190184
38	3 606 337 212	1	PLANETARY-GEAR CARRIER	205975
41	3 600 905 027	1	DEEP-GROOVE BALL BEARING	190183
42	3 600 301 012	1	INNER RING	X
44	3 600 301 011	1	SINTERED-METAL BUSHING	205976
46	3 603 344 054	1	THREADED RING	190008
56	3 605 190 193	1	CONNECTION HOUSING	189628
57	3 600 400 004	1	PROTECTION SLEEVE	203042
60	3 600 002 001	2	STRAINER	190006
66	3 604 710 000	1	STRAIGHT PIN	189625
77	3 603 203 004	1	HOLDING PIN	202386
78	3 603 231 000	1	VALVE CONE	202385
86	3 603 435 032	1	ADJUSTING SCREW	189652
87	3 600 210 015	1	O-RING / 4x1 MM	189648
90	3 607 000 023	1	SILENCER	189606
95	3 601 106 047	1	NAMEPLATE	X
96	3 601 110 331	1	MANUFACTURER'S NAMEPLATE	X
802	3 607 031 016	1	ASSEMBLY OF SERVICE PARTS	190180
804	3 607 030 249	1	ASSEMBLY OF SERVICE PARTS	189626
818	3 607 010 007	1	PARTS SET / 10 PIECE	190019
855	3 607 010 020	1	PARTS SET / 10 PIECE	202384

BOSCH 0 607 951 451 – A000034
401-0004
TENSION MOTOR
PHT801

0 607 951 440
 Issue 04-08-12
 Stand

Fig./Abb. 1

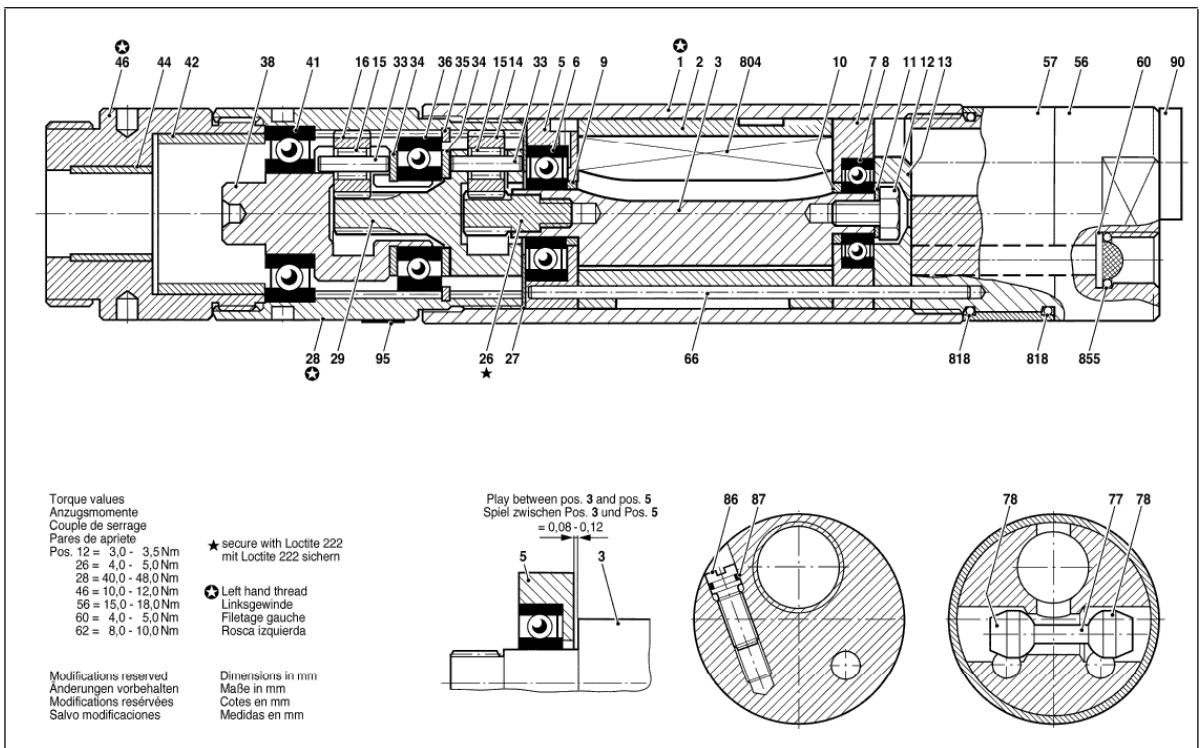
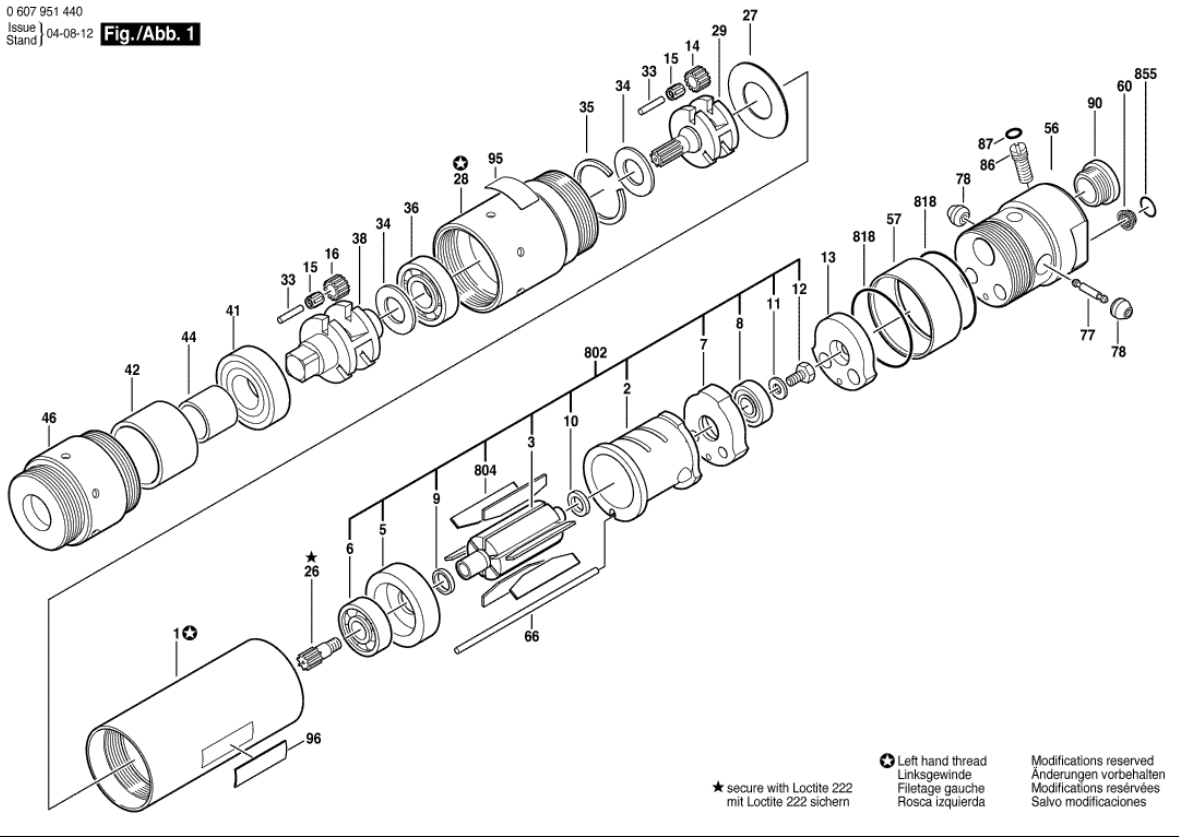

SPARE PARTS LIST A000034 (401-0004)

Nr.	CODE	QTY	DESCRIPTION	JDE PART #
1	3 600 760 114	1	MOTOR HOUSING / BLUE	189730
2	3 604 090 002	1	STATOR / 370W	X
3	3 604 220 025	1	ROTOR	206631
5	3 605 700 005	1	BEARING FLANGE	189728
6	3 600 905 039	1	DEEP-GROOVE BALL BEARING / 9x24x7mm	190004
7	3 605 700 006	1	BEARING FLANGE	205673
8	3 600 905 148	1	DEEP-GROOVE BALL BEARING / DIN 625-7x19x6	190005
9	2 600 202 013	1	SPACER RING	206629
10	2 600 202 014	1	SPACER RING	206630
11	2 916 011 012	1	PLAIN WASHER / DIN 125-A5,3-ST	190192
12	2 911 061 150	1	HEX SCREW / DIN 933-M5x8-8.8	X
13	3 602 305 000	1	INTERMEDIATE PIECE	189627
	3 606 316 003			190182
15	3 600 913 000	6	NEEDLE-ROLLER ASSEMBLY / INA K3x5x7	189781
	3 606 316 003			190182
16	3 606 316 002	3	CYLINDRICAL GEAR / Z=18	X
26	3 606 300 003	1	PINION / Z=11	X
27	3 600 101 001	1	STOP DISC	X
28	3 606 334 000	1	RING GEAR / Z=49	207204
29	3 606 337 004	1	PLANETARY-GEAR CARRIER	X
	3 606 337 124			
33	3 603 201 000	6	NEEDLE ROLLER	205974
34	3 600 103 002	2	SHIM RING	206197
35	3 600 224 000	1	RETAINING RING	X
36	1 900 900 287	1	DEEP-GROOVE BALL BEARING / 6001 DIN 625	190184
38	3 606 337 212	1	PLANETARY-GEAR CARRIER	205975
41	3 600 905 027	1	DEEP-GROOVE BALL BEARING	190183
42	3 600 301 012	1	INNER RING	X
44	3 600 301 011	1	SINTERED-METAL BUSHING	205976
46	3 603 344 054	1	THREADED RING	190008
56	3 605 190 193	1	CONNECTION HOUSING	189628
57	3 600 400 004	1	PROTECTION SLEEVE	203042
60	3 600 002 001	2	STRAINER	190006
66	3 604 710 000	1	STRAIGHT PIN	189625
77	3 603 203 004	1	HOLDING PIN	202386
78	3 603 231 000	1	VALVE CONE	202385
86	3 603 435 032	1	ADJUSTING SCREW	189652
87	3 600 210 015	1	O-RING / 4x1mm	189648
90	3 607 000 023	1	SILENCER	189606
95	3 601 106 047	1	NAMEPLATE	X
96	3 601 110 331	1	MANUFACTURER'S NAMEPLATE	X
	3 601 119 236			
802	3 607 031 016	1	ASSEMBLY OF SERVICE PARTS	190180
804	3 607 030 249	1	ASSEMBLY OF SERVICE PARTS	189626
818	3 607 010 007	1	PARTS SET / 10 PIECE	190019
855	3 607 010 020	1	PARTS SET / 10 PIECE	202384

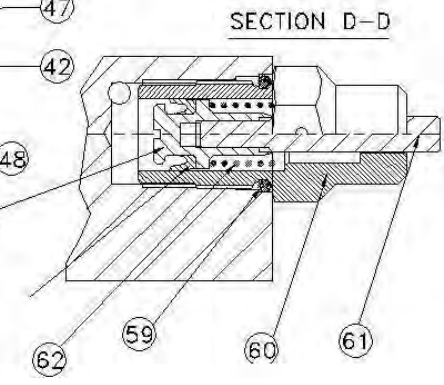
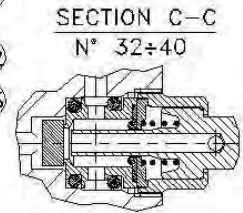
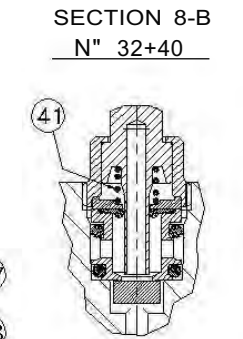
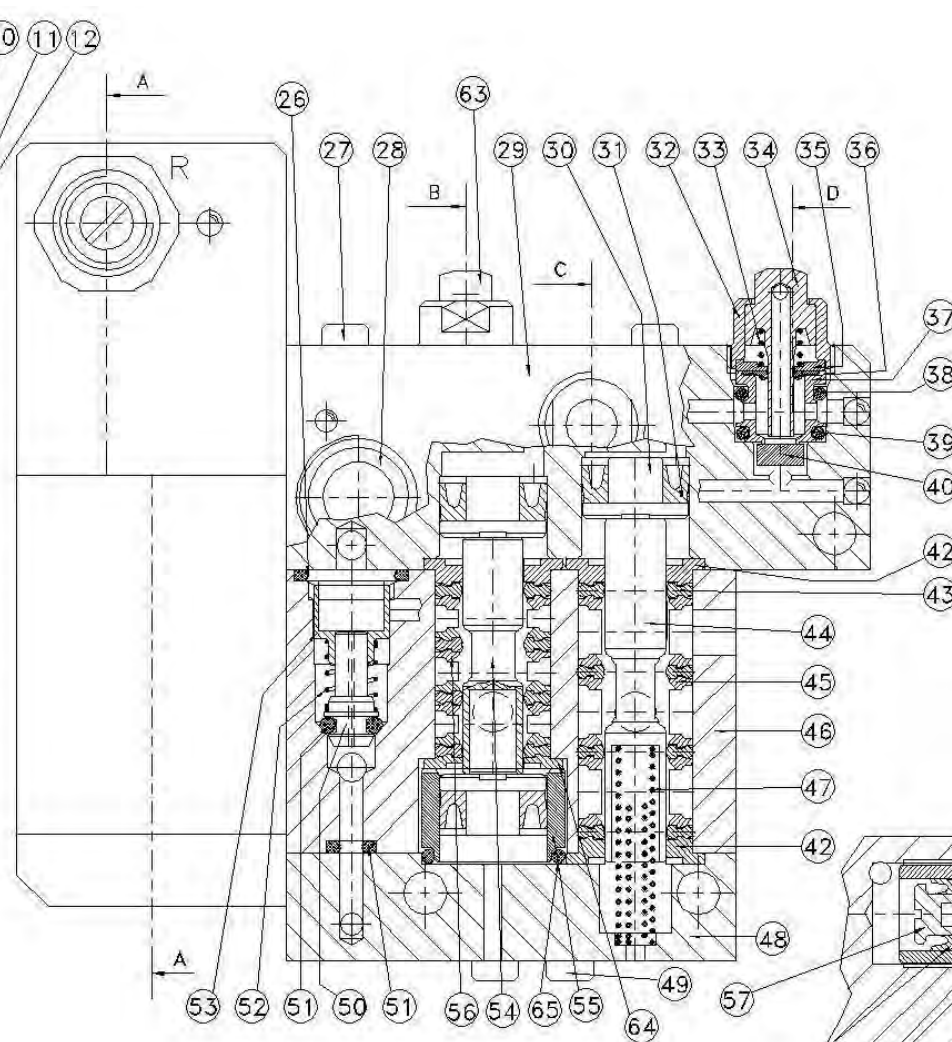
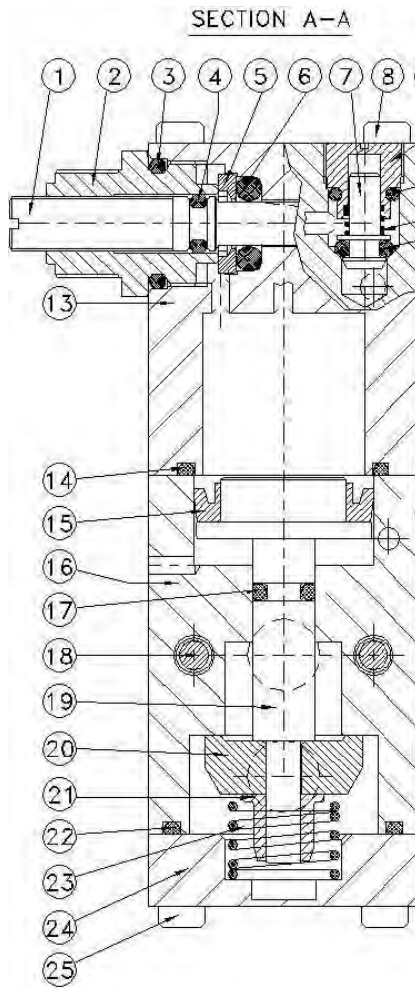

SPARE PARTS LIST B200347 (400-8011)

11.028.0

CODICE / CODE	GREENBRIDG EPART #	DESCRIPTION	Q.TY
AX.035.0		SPRING PISTOM RESET	1
BF.056.0		SPACER 1mm	2
1.82.M75	190007	SHUTTER SH75	3
10.204.1		TIMER CONTROL TOP PLATE	1
10.040.1		BODY TIMER	1
10.165.1		TIMER BOTTTOM PLATE	1
10.205.0		PISTON FOR TIMER ADJUSTMENT	1
10.206.1		PERFORATED CAP 0.1mm	1
08.254.0		SINTERED FILTER	1
11.014.0		SPRING	1
21.498.0	189495	GASKET	1
10.051.2	190016	PISTON ASSEMBLY O20 INCLUDING -10.182.0 : PISTON -01.014.0 : LIP GASKET -OR4X1 : O-RING -	1
03.032.0	189711	SHUTTER	1
03.025.0		PISTON 020 SPRING GUIDE	1
01.014.0		PISTON LIP GASKET Oe20	1
11.004.0	190002	SPRING	1
08.031.2		SPACER KIT WITH OR105 + OR106	3
08.004.OP		SPACER	3
08.013.1T		BUTTON GUIDE	3
08.008.0		GASKET HOLDER	3
08.007.N	189304	OR WITH MEMBRANE	3
08.112.0		MICROVALVE SPRING	1
08.023.1	204101	BUTTON WITHOUT HOLE	1
11.028.0		LIP GASKET 08	1
20.004.0	189999	CYLINDER SPRING	1
20.000.0		PISTON 08	1
11.001.0	189686	SHUTTER GUIDE	1
00.364.0	203646	LEFT SPRING	1
10.017.0	189687	SHUTTER VNR 1/8 HOLE 00,5	1
00.365.0	203647	RIGHT SPRING	1
00.112.2		PISTON KIT 012	3
00.018.0		LIP GASKET 0e12	3
00.013.0		PISTON 012	3
05.101.1		SHUTTLE 3/2 FOR VALVE	1
00.010.0T		SHUTTLE 3/2 – 1/8	1
00.008.0		GASKET HOLDER 015,5 – 1/8	2
00.433.0		GASKET HOLDER 015,5 – 1/8	2
00.002.0	19771	SPACER	3
00.001.0		GASKET	8
05.113.0	189634	SPACER	3
00.407.0		PIPE 8 CARTRIDGE	4
08.010.1T	202049	BUTTON	2
08.006.0	189632	BUTTON SPRING	2
00.432.0		REDUCTION	1
10.142.1		BODY 3 WAY DOUBLE VALVE	1
10.143.1		CONTROL WITH BUTTONS	1
10.144.1		BOTTOM PLATE	1
20.001.0		COOLING TIME INDICATOR	1
20.002.0	189996	CYLINDER BODY 08	1
OR4X1		O-RING 4X1	2
OR101	189947	O-RING OR 101	4
OR102	189499	O-RING OR102	4
OR104		O-RING 104	2
OR105		O-RING 105	1
OR106		O-RING 106	1
OR108		O-RING 108	4

OR110	189295	O-RING OR110	1
OR2043	189296	O-RING OR 2043	1
OR2050	189922	O-RING OR2050	1
OR2087		O-RING OR 2087 TIMER PLATE	1
OR2093		O-RING OR TIMER BOTTOM PLATE	1
M4X10		SCREW M4x10 UNI5931	2
M4X12		SCREW M4X12 UN15931 VALVE BOTTOM PLATE	2
M4X25		SCREW M4x25 UNI5931 VALVE TOP PLATE	2
M4X30		SCREW M4x30 UNI5931 MOUNTING TIMER	2
M4X4		SCREW M4x40 UN15931 (TIMER BOTT. PLATE)	2

CE DECLARATION OF CONFORMITY

Greenbridge declares under own responsibility that the under mentioned machinery, to which this declarations refers, is in conformity with **2006/42/CE** Directive and successive modifications, as well as with standards **EN12100-1 / EN12100-2**

MODEL:
Series PHT801/1201



MACHINE TYPE:

PNEUMATIC PLASTIC STRAPPING TOOL

GREENBRIDGE

6277 Heisley Road Mentor, Ohio 44060

Tel. 440-357-1500 Fax 440-352-9553 www.greenbridge.com

